

Watson 2 Rev. E

LTU/NTU

Operating Manual

Document Identification	SZ.DOC.W2E.3.pdf
Document Version	1.2
Document Revision	3.11. 2000

Version Control

Version of Operating Manual	Major changes to previous version
0.9	Creation, SSt, UFh.
1.0	Revised Version, CTa.
1.1	Description of the Commands: RESET and STOPAL, for the Dual LTU, CTa.
1.2	Operating voltage range corrected; Nx64 kbit/s, E1, Installation Guide, CE, Safety, structure according W3/4, remote powering part, LSs, RAn TMN Interface and Minirack address features added, URr

Copyright 2000 by Schmid Telecommunication, Zurich, Switzerland. All rights reserved. Reproduction of part or all of the contents in any form is expressly prohibited without the prior written consent of Schmid Telecommunication.

Schmid Telecommunication has used its discretion, best judgments and efforts in preparing this document. Any information contained in this document is provided without any warranty of any kind. Schmid Telecommunication hereby disclaims any liability to any person for any kind of damage. Schmid Telecommunication may make improvements and/or changes of this document at any time.

Declaration of Conformity

	Watson 2	LTU, E1, Rev.E, with 19" subrack SZ.379.V3	SZ.363.V510, SZ.363.V530
		LTU, 2*E1, Rev.E, with 19" subrack SZ.379.V3	SZ.363.V511, SZ.363.V533
		NTU, E1, Rev.E, tabletop	SZ.364.V510, SZ.364.V530
		NTU, nx64, Rev.E, tabletop	SZ.364.V580
		LTU, 2*E1, Rev.E, minirack	SZ.798.V511, SZ.798.V533
		NTU, E1, Rev.E, minirack	SZ.795.V510, SZ.795.V530
		NTU, nx64, Rev.E, minirack	SZ.795.V580
	REG with housing	SZ.372.V3, SZ.371.V3, SZ.371.V2	SZ.372.V2

Manufacturer: Schmid Telecom AG
Binzstrasse 35
CH-8045 Zurich

The products mentioned above comply with the regulations of the following European Directives:

89/336/EEC Directive containing requirements in respect with electro-magnetic compatibility.	The compliance of the above mentioned product with the requirements of the directive 89/336/EEC is ensured by complete application of the following harmonized European Standards: EN 300386-2 (1998)
73/23/EEC Directive containing requirements in respect with safety requirements.	The compliance of the above mentioned product with the requirements of the directive 73/23/EEC is ensured by complete application of the following harmonized European Standards: EN 60950/A4 (1997)
99/5/EEC Directive containing requirements in respect with Radio & Telecommunication Terminal Equipment.	The compliance of the above mentioned product with the requirements of the directive 99/5/EEC is ensured by complete application of the following harmonized European Standards: EN 300386-2 (1998) EN 60950/A4 (1997)

The compliance of the above mentioned products with the specified requirements of the applicable directives and harmonized and non-harmonized standards is shown in the following internal and external test reports: SZ.QDOC.W2E.pdf and W2E_Test_Reports.pdf

CE Label attached to the product(s): on minirack, on tabletop, on 19" subrack (for LTU only)
Issued by: Schmid Telecom AG
Binzstrasse 35
CH-8045 Zurich
Place and date: Zurich, 3.11.2000

Signatures:

Signature 1



Dr. Lothar Schultheis

Signature 2



Walter Büchel

Contents

1	The Watson 2 Family	1
2	General Information	3
2.1	Important Safeguards	3
2.2	Ordering Information.....	5
2.2.1	LTU.....	5
2.2.2	NTU.....	5
2.2.3	REG.....	6
2.2.4	Accessories.....	6
3	Installation Guide	7
3.1	Preparations	7
3.2	Installing a Watson Modem.....	7
3.3	Installation Requirements.....	9
4	Interface Configuration Options	11
4.1	DSL.....	11
4.1.1	Master / Slave	11
4.1.2	HDSL Operating Modes.....	12
4.1.3	Autorestart.....	13
4.1.4	Time Slot Mapping	13
4.2	E1 Interface (2 Mbit/s G.703 / G.704)	14
4.2.1	Framing.....	14
4.2.1.1	Transparent Mode	14
4.2.1.2	Framed Mode ITU-T G.704	14
4.2.1.2.1	CRC4.....	14
4.2.1.2.2	E-bit Insertion	15
4.2.2	AIS Generation	15
4.2.3	AIS Detection.....	15
4.2.4	E1 Clock Modes.....	15
4.2.4.1	Clock Sources	15
4.2.4.2	External Clock Mode.....	17
4.3	ISDN PRA Interface	18
4.3.1	PRA Mode.....	19
4.3.2	CRC4 Processing Options	19
4.3.2.1	Digital Link without CRC Processing (Option 1)	19
4.3.2.2	Digital Link with CRC Processing in the NT1 (Option 2).....	20
4.3.2.3	Digital Link with CRC Processing in the LT and NT1 (Option 3)	22
4.3.2.4	Digital Link with CRC Monitoring in the NT1 (Option 4).....	22
4.3.3	Generation of CRC4 Error Notifications to the ET.....	23

4.4	n x 64kbit/s Interface	24
4.4.1	Features.....	24
4.4.2	Configuration	25
4.4.2.1	Time Slot Mapping.....	25
4.4.2.1.1	Terminology	25
4.4.2.1.2	n x 64kbit/s Time Slot Mapping.....	25
4.4.2.1.3	E1 Time Slot Mapping.....	26
4.4.2.2	User Interface Type.....	26
4.4.2.3	Bit Rate.....	26
4.4.2.4	Clock Mode.....	26
4.4.2.5	Clock Direction.....	28
4.4.2.6	V.54 Loops and Loop Control.....	28
4.4.2.6.1	Normal Handshake Operation.....	28
4.4.2.6.2	Supported V.54 Loops	29
4.4.2.6.3	Automatic Loop Control through the DTE/DCE Interface	29
4.4.2.7	Byte Timing.....	29
4.5	TMN Interface (Minirack LTU only).....	30
4.5.1	TIA/EIA-485 4-wire Bus	30
4.5.2	TIA/EIA-485 2-wire Bus	31
4.5.3	TIA/EIA-485 Bus Termination	33
5	Performance Monitoring	35
5.1	Noise Margin	35
5.2	G.826 Performance Monitoring	35
5.2.1	DSL Interface	36
5.2.2	E1 Interface.....	37
5.2.3	ISDN PRA Interface.....	38
6	Alarms 39	
6.1	LEDs.....	39
6.1.1	Status LEDs	40
6.1.2	Alarm Conditions	40
6.1.2.1	Local LED	40
6.1.2.2	Remote LED	41
6.2	Alarm Relays	42
6.2.1	LTU.....	42
6.2.1.1	Alarm Conditions.....	42
6.2.2	NTU.....	43
6.2.2.1	Alarm Conditions.....	43
7	Power Concept	45
7.1	LTU.....	45
7.1.1	Power and Grounding	45
7.2	NTU.....	45
7.2.1	Power and Grounding	45
7.2.2	Power Failure Alarm.....	46
7.3	Remote Powering	46
8	Monitor 51	
8.1	General	51
8.2	Addressing	51
8.2.1	LTU.....	51
8.2.2	LTU Minirack.....	54
8.2.3	NTU.....	54
8.3	Structure and Organization	54

8.3.1	Performance Management PM.....	55
8.3.1.1	G826 Command	56
8.3.1.2	RESETG826 Command.....	61
8.3.2	Fault and Maintenance Management FMM.....	61
8.3.2.1	SQ Command	62
8.3.2.2	SQ REGn Command	62
8.3.2.3	STARTUP Command.....	63
8.3.2.4	STATUS Command	64
8.3.2.5	STATUS REGn Command	67
8.3.2.6	ALARM Command.....	68
8.3.2.7	ACO Command.....	70
8.3.2.8	LOOP1 Command	70
8.3.2.9	LOOP2 Command	71
8.3.2.10	LOOPREGn Command.....	71
8.3.2.11	STARTAL Command	71
8.3.2.12	STOPAL Command	72
8.3.2.13	TRACETIME Command.....	72
8.3.2.14	RESET Command	72
8.3.3	Configuration Management CM.....	72
8.3.3.1	CONFIG Command	73
8.3.3.2	Configuration Commands.....	74
8.3.3.3	DEFAULT Command	76
8.3.3.4	REMOTE Command.....	81
8.3.3.5	COPY Command.....	82
8.3.3.6	LOCAL Command	82
8.3.4	Accounting Management AM.....	82
8.3.5	Security Management SM.....	82
8.4	Monitor Commands for the n x 64kbit/s Interface.....	82
8.4.1	Fault and Maintenance Management FMM.....	83
8.4.1.1	ALARM Command.....	83
8.4.2	Configuration Management CM.....	83
8.4.2.1	CONFIG Command	84
8.4.2.2	BITRATE Command	85
8.4.2.3	CLOCKMODE Command.....	85
8.4.2.4	CLOCKDIR Command.....	85
8.4.2.5	V54LOOPS Command.....	85
8.4.2.6	BYTETIMING Command.....	85
8.4.2.7	UIF Command.....	85
8.4.2.8	DEFAULT Command	85
8.4.2.9	COPY Command.....	87
8.5	Monitor Commands for LTU Minirack TMN Interface.....	88
8.5.1	ADDRESS Command.....	88
8.5.2	V11WIRES Command.....	90
9	Front and Rear Panel Description	93
9.1	Tabletop NTU, Rear Panel.....	94
9.2	Minirack NTU, Front Panel.....	94
9.3	Plug-in LTU, Front Panel.....	96
9.4	Minirack LTU, Front Panel	99
10	Connectors' Description	101
10.1	DSL Connector	102
10.2	E1 Connector.....	103
10.2.1	Impedance 120Ω	103
10.2.2	Impedance 75Ω	105
10.3	n x 64kbit/s Connector	105

10.3.1	User Interface Type	105
10.3.2	n x 64kbit/s Cables.....	108
10.3.2.1	V.35 DTE Cable	108
10.3.2.2	V.35 DCE Cable.....	109
10.3.2.3	V.36 DTE Cable	110
10.3.2.4	V.36 DCE Cable.....	111
10.3.2.5	X.21 DTE Cable	112
10.3.2.6	X.21 DCE Cable.....	113
10.4	Monitor Connector (NTU).....	115
10.5	Monitor Connector (LTU in Minirack)	115
10.6	48V _{DC} Power Connector (NTU)	116
10.7	48V _{DC} Supply (Minirack).....	117
10.7.1	Mains Connector (Minirack LTU only).....	117
10.7.2	2048kHz Input (Minirack LTU only)	117
10.7.3	TMN Alarms (Minirack LTU only)	118
11	Technical Specifications	119
11.1	Interfaces	119
11.1.1	DSL Line Interface.....	119
11.1.2	User Interface.....	120
11.1.3	Monitor Interface.....	121
11.1.4	TMN and Alarm Interface (Minirack LTU Only).....	121
11.1.5	The 230/115V _{rms} and 48V _{DC} Supply of the Minirack.....	121
11.1.6	External Clock.....	122
11.2	Power Supply	122
11.2.1	LTU.....	122
11.2.2	NTU.....	123
11.2.3	REG.....	123
11.3	Environment	123
11.3.1	Climatic Conditions	123
11.3.2	Safety	123
11.3.3	EMC	123
11.4	Physical Dimensions.....	124
11.4.1	LTU.....	124
11.4.2	NTU.....	124
12	Diagnostics and Troubleshooting.....	125
12.1	Test Loops.....	125
12.2	Hints for Troubleshooting.....	127
13	Appendix 129	
13.1	Abbreviations.....	129
13.2	Referenced Documents.....	132

Figures

Figure 4-1:	Clock Sources.....	16
Figure 4-2:	Synchronous Operation (=“Loop Timing”).....	16
Figure 4-3:	External Clock Mode.....	17
Figure 4-4:	Reference Points of the PRA.....	18
Figure 4-5:	Digital Link without CRC Processing.....	20
Figure 4-6:	Digital Link with CRC Processing in the NT1	21
Figure 4-7:	Digital Link with CRC Processing in the LT and NT1	22

Figure 4-8: Digital Link with CRC Monitoring in the NT1	23
Figure 4-9: TMN bus 4-wire connection for Minirack units.....	30
Figure 4-10: TMN bus 2-wire connection for Minirack units.....	31
Figure 4-11: TMN bus 2-wire connection for Plug-in units.....	32
Figure 4-12: Termination for long TMN bus.....	34
Figure 5-13: Regenerator G.826 Performance Evaluation.....	36
Figure 5-14: E1 G.826 Performance Evaluation	37
Figure 5-15: PRA G.826 Performance Evaluation	38
Figure 7-16: Line feed current vs loop resistance for different NTU power consumptions.....	48
Figure 7-17: LTU powers one REG and one NTU: Line feed current vs loop resistance two different REG power consumptions.....	48
Figure 7-18: LTU powers two REGs: Line feed current vs loop resistance two different REG power consumptions.....	49
Figure 8-19: LTU Interface Addressing Scheme	53
Figure 12-20: Standard Test Loops	125
Figure 12-21: Regenerator Loopback.....	126
Figure 12-22: Regenerator in Loopback Mode	127

1 The Watson 2 Family

The Watson II family is a 2B1Q based 2-pair HDSL-System. It was designed with flexibility and modularity in mind. It supports both full and fractional E1 data rates, in either framed or transparent mode and ISDN Primary-Rate-Access (PRA).

The Line-Termination-Units (LTU) are available as 19" subrack card or as minirack version (only Dual LTU version). The LTU may be configured (jumper) as LTU-L or LTU-R. The LTU-R is capable of remotely powering a remote NTU-R and a regenerator (i.e. the LTU-R is a remote power source). The LTU-R is only master configurable, whereas the LTU-L is both master and slave configurable.

The regenerator has to be remotely powered via the HDSL line and is available with different housings for outdoor and underground installation.

The Network-Termination-Unit (NTU) is available as a table-top unit or as a minirack version. The NTU may be configured by a slide switch as either NTU-R or NTU-L. An NTU-R is remotely powered by an LTU-R, whereas an NTU-L is powered by a 230V/48V mains adapter.

An Alarm Control Unit (ACU) in the subrack enables the connection of the EIA485-bus, the EIA232 Monitor interface, and the alarm relays.

An optional Control and Management Unit (CMU) in the 19" subrack acts as an SNMP agent and brings TMN facilities to the system.

2 General Information

2.1 Important Safeguards

This section describes the safety precautions the user should abide by when operating this equipment.

- Transport this equipment in its original packaging or by using appropriate materials to prevent against shock and impact,
- Before setting up this product for operation please make note of the accompanying environmental requirements.
- Slots and openings in the unit are provided for ventilation. To ensure reliable operation and to protect it from overheating these slots and openings must not be blocked or covered.
- Condensation may occur externally or internally if this equipment is moved from a colder room to a warmer room. When moving this equipment under such conditions, allow ample time for the equipment to reach room temperature and to dry before operating.
- Note that normal operation (in accordance with EN 60950) is only possible when the external housing is left in place (ventilation, fire prevention, and radio interference).
- Before supplying power, verify the power rating identified on the marking label complies with the local power source.
- Do not allow anything to rest on any of the attached cables and do not locate the product where persons will walk or trip on the cables.
- Connect this equipment only to an approved, properly grounded, and accessible socket outlet. To completely turn off this equipment you must remove the power cord from the system.
- Avoid connecting or disconnecting data lines during lightning storms.
- Follow the accompanying instructions when connecting the required cabling.
- Make sure no foreign objects or liquids come into contact with the internal components (danger of shock or short circuit).
- In an emergency (e.g., damaged external housing or internal elements, liquid spills) immediately remove the power cord and notify customer service.
- Electrostatic electricity can damage internal components. Ground yourself before touching any internal components.

- Never use water to clean this device. If water reaches the internal parts, extreme danger may result to the user or the equipment.
- Never use scouring or abrasive cleaning agents, or agents containing alkaline on device. Damage of the device's exterior may result.

Information for the Technician

- Remove the network cables before opening this equipment or removing the plug-in units, respectively.

Safety Notices

Do not proceed any of these notices until you have fully understood the implications:

- Caution! Potential hazard that can damage the product.
- Important! Potential hazard that can seriously impair operation.

2.2 Ordering Information

2.2.1 LTU

Model	Description	Product Number
Plug-in	W2 LTU-L/R E1 120Ω	SZ.363.V510x
	W2 LTU-L/R E1 75Ω	SZ.363.V530x
	W2 Dual LTU-L/R 2xE1 120Ω	SZ.363.V511x
	W2 Dual LTU-L/R 2xE1 75Ω	SZ.363.V533x
Minirack	W2 Dual LTU-L/R 2xE1 120Ω	SZ.798.V511x
	W2 Dual LTU-L/R 2xE1 75Ω	SZ.798.V533x

2.2.2 NTU

Model	Description	Product Number
Table-top	W2 NTU-L/R E1 120Ω	SZ.364.V510x
	W2 NTU-L/R E1 75Ω	SZ.364.V530x
	W2 NTU-L/R nx64	SZ.364.V580x
Minirack	W2 NTU-L/R 2xE1 120Ω	SZ.795.V510x
	W2 NTU-L/R 2xE1 75Ω	SZ.795.V530x
	W2 NTU-L/R nx64	SZ.795.V580x

Notes:

x = W, as a default for the general version

x = other letter than W standing for customer-specific version

2.2.3 REG

Description	Product Number
W2 regenerator unit	SZ.372.V2x
W2 regenerator case (open air, ground installation) for 4 REG	SZ.372.V3x
W2 regenerator outdoor case IP66, for 1 REG	SZ.371.V2x
W2 regenerator outdoor case IP55, for 2 REG	SZ.371.V3x

2.2.4 Accessories

Subrack	SZ.379.V3W
ACU2R	SZ.369.V5W
ACU48R	SZ.369.V4F
Nx64kbit/s Cables	
V.35 DTE, 3m length	SZ.378.0F1.V1
V.35 DCE, 3m length	SZ.378.0G1.V1
V.36 DTE, 3m length	SZ.378.0H1.V1
V.36 DCE, 3m length	SZ.378.0J1.V1
X.21 DTE, 3m length	SZ.378.0K1.V1
X.21 DCE, 3m length	SZ.378.0L1.V1
AC/DC Adapter, 230V version	SZ.378.0A0.V1
AC/DC Adapter, 115V version	SZ.378.0A0.V3
DC/DC Adapter, 48/60V	SZ.378.0A0.V5

3 Installation Guide

This chapter gives a brief overview over the necessary steps to install a Watson modem.

3.1 Preparations

Before going to the installation site, check what you need of the following equipment in addition to the modem:

- AC/DC Power adapter or supply cable (for tabletop or minirack NTU)
- DSL cable
- Network cable
- Monitor cable and terminal
- Mounting material

In case your installation requires special DSL cabling or rack mounting, check what you need of the following tools:

- Wire stripping tool appropriate for the cable size.
- Crimp tools for connectors
- Screwdrivers

3.2 Installing a Watson Modem

- Unpack and mount the unit safely. Keep chapter "Important Safeguards" in mind when choosing an appropriate place for tabletops. Miniracks can be mounted in 19" racks.
- Plug-in units are simply inserted into subracks and will start operation immediately. Mounting of subracks is described in manual "Installation Manual of Subrack".
- Check the setting of the remote power switch/jumper.

NTU In the default switch position "Rem", the NTU modem is powered via the xDSL line and will start operation immediately after connection of the xDSL line. In case the remote LTU modem does not support power feeding, local power supply is needed for operation. In position "Loc", the NTU modem is powered locally and needs the power supply connected to operate.

LTU In the default jumper positions "RPWR A ON", "RPWR B ON", .. the LTU

modem is powering the remote NTU unit. In jumper position "OFF", the remote powering function is disabled.

Caution: LTUs must be disconnected from power during change of jumper setting. See chapter "Power concept"; section "Remote powering" for further information.

- Connect the modem to the network or PC. Plug the appropriate cable to the interface connector on the unit. Refer to chapter "Connectors' Description" for cable definitions.
- Connect the modem to the DSL line. If using a preconfigured cable, just connect the xDSL line with male RJ45 cable into the female RJ45 connector of the modem. If you need to configure the cable, refer to chapter 10 "Connector Description"; section "DSL Connector".
- NTUs in remote power mode will start operation immediately with factory default settings, and further configuration is optional.
- Optional: Connect the power supply. For local power supply of NTUs, connect the AD/DC power adapter (ordered separately) to the mains and to the unit. The power adapter is optional for NTUs in remote power mode. Minirack LTUs can be connected directly to mains, to a 48V_{DC} source or both at the same time. Plug-in units are powered via the subrack backplane. See chapter "Power concept" for further information.
- Optional: Configure the unit. Connect a VT100 terminal using the serial monitor cable to the "Monitor" connector of the unit or of the subrack.

Important: Check DSL mode configuration "master/slave". There must be a "master" unit connected to a "slave" unit for proper operation. The configuration of a "slave" unit can also be done via the "master" unit. Refer to chapter "Monitor Operation" for detailed information.

- Check the proper operation. The LED "Local" lights green in normal operation. In "slave" mode, the LED "Remote" is off, but should light green for normal operation in "master" mode. See chapter "Alarm Indication" for further information.

Watson modems are generally very easy to install; usually just plugged to the DSL line and to the network. If more configuration is needed, the operator is supported by comprehensible menus, default settings, plausibility checks and helpful warning messages. This way, the operator can easily control the wealth of powerful functions that Watson modems provide.

3.3 Installation Requirements

Installation of this equipment has to be done by qualified personnel only.

To achieve safety and satisfactory EMC performance, the plug-in LTU has to be inserted into the subrack. Subrack slots that are not used have to be covered with blanking plates.

The subrack or minirack must be bonded to earth. This is usually achieved by installing the subrack or minirack into a rack which is connected to the earthing network according to ETS 300 253.

Additionally, on the subrack an extra earth terminal for connection to the FPE connector (Functional Protective Earth) is provided.

4 Interface Configuration Options

The following sections describe the various configuration options. On the plug-in LTU, the operating modes are configurable via the V.24 monitor interface or via the TMN interface of the ACU, whereas on the minirack LTU, table-top NTU and minirack NTU, they are directly configurable via the monitor interface. If the LTU/NTU is slave, it is also configurable from the master side. Only the remote/local powering has to be configured via jumpers on the board of the LTU or via slide switches on the NTU.

4.1 DSL

The following configuration options refer to the DSL side and do not affect the user interface operating mode except in case of Fractional, Partial, or Hot Standby operation.

4.1.1 Master / Slave

To start up a DSL link, one system unit must be configured as master and the other one as slave. The link start-up procedure is controlled by the master. **If both system units are configured as master or as slave, no start-up will occur.**

Usually, the LTU is configured as master and the NTU as slave (default setting). However, it is possible to set up a DSL link with two LTUs or two NTUs, as long as one is configured as master and the other one as slave. In these cases, remote powering is not possible.

Generally, the master-slave permissions are:

- The slave unit has only the permission to change its own configuration locally. It cannot access nor modify the master unit's configuration or data. Access to the slave unit's configuration or data is possible via local monitor or via the master unit.
- The master unit has local access as well as remote access to the slave unit. For safety reasons, only the master / slave configuration and the autorestart option cannot be altered by the master unit over the DSL link.

When the "Remote" LED on the front panel of the NTU is lit, the system unit is configured as master.

4.1.2 HDSL Operating Modes

In this section the various operating modes of the HDSL transceiver pairs are described.

In Fractional, Partial and Hot Standby mode, remote power feeding is not available since the NTU consumes more power than can be supplied over a single pair on long loops with high DC resistance.

In Normal mode, there are no restrictions on configuration options.

For Fractional and Partial operation mode, also refer to ETSI TS 101 135, sections 7.4 and 7.5.

Normal Mode:

In Normal mode, startup and operation of the two HDSL channels (pairs) are synchronized to each other. Therefore, if one of the two HDSL channels fails, both channels are restarted and data transmission is interrupted until both channels have been reactivated.

Fractional Mode:

In Fractional mode, only HDSL channel A is in operation while the transceiver of channel B is switched off. Only time slots TS0-TS17 of the application frame are transmitted while the unused time slots TS18-TS31 are refilled with all-ones (AIS) at the receive end.

Partial Mode:

In Partial mode, startup and operation of the two HDSL channels (pairs) are not synchronized to each other. Therefore, if one of the HDSL channels fails, only the failed channel is restarted while the other channel continues data transmission.

Time slots TS0-TS17 of the application frame are assigned high priority and TS18-TS31 low priority. Therefore, if one of the HDSL channels fails, time slots TS0-TS17 are dynamically reallocated to the remaining active channel while time slots TS18-TS31 are filled with AIS until the failed channel has been reactivated.

If the HDSL channel carrying time slots TS0-TS17 fails, high priority data may be corrupted for a short time only, due to the reallocation procedure. If the HDSL channel carrying time slots TS18-TS31 fails, high priority data will not be corrupted at all.

Hot Standby Mode:

In Hot Standby mode, startup and operation of the two HDSL channels (pairs) are performed in the same way as in Partial mode, except that both channels are carrying time slots TS0-TS17 of the application frame redundantly. The unused time slots TS18-TS31 are filled with all-ones (AIS) at the receive end.

If the active channel fails, the receivers will immediately switch to the standby channel and application data may be lost for a short time only, due to the reallocation procedure. If the standby channel fails, only this channel is restarted and no application data will be lost.

4.1.3 Autorestart

This option enables / disables automatic DSL channel restart according to the ETSI TS 101 135. This specifies an automatic DSL restart after a 2s loss of DSL synchronization.

4.1.4 Time Slot Mapping

User interface time slots are mapped onto the DSL frame according to ETSI TS 101 135.

4.2 E1 Interface (2 Mbit/s G.703 / G.704)

4.2.1 Framing

4.2.1.1 Transparent Mode

In transparent mode, the E1 data will be transmitted without any changes, whereas in framed mode, the frame / multiframe alignment words and CRC4 bits are regenerated by the E1 framer.

The “CRC4 “ and “E-bit Insertion” options are not relevant in transparent mode.

4.2.1.2 Framed Mode ITU-T G.704

In framed mode (framing according to ITU-T G.704), the incoming E1 data stream passes through an E1 framer before entering the DSL section. From the other side, the same process happens in reverse; the E1 data stream received from the DSL section first passes through the E1 framer before being transmitted to the E1 network.

The E1 framer operates in Common Channel Signaling (CCS) mode. Time slot 16 and all national bits are fully transparent.

Consider the “CRC4” and “E-bit Insertion” options when operating in framed mode.

4.2.1.2.1 CRC4

If operating in framed mode, the “CRC4” option can be used to adapt to specific E1 network requirements:

- If enabled, the E1 framer will synchronize on CRC4 multiframes and CRC4 errors will be reported. In the outgoing E1 signal the framer regenerates the CRC4 multiframe alignment and checksum words. The A-Bit and the Sa-Bits pass transparently.
- If disabled, the international bits are set to ‘1’ in the outgoing E1 signal. All national bits are fully transparent. On the receive side, the E1 framer will synchronize on basic frames only and no CRC4 errors will be reported.

4.2.1.2.2 E-bit Insertion

- If automatic E-Bit generation is enabled, detected CRC4 errors will cause the assertion of the E-bits.
- If disabled, all E-Bits are set to ‘1’.

4.2.2 AIS Generation

If this option is enabled, an unframed AIS (all ones) will be transmitted on the E1 side, irrespective of whether the system is configured in transparent or framed mode. AIS generation will be activated on the following conditions:

- DSL link to the remote station is not established (loss of signal or loss of frame alignment on DSL side) or
- remote station is sending AIS-R.

If AIS generation is disabled, no signal will be transmitted on the E1 side if either of these two conditions occurs.

4.2.3 AIS Detection

If AIS detection is enabled, receiving AIS from the E1 side will cause the following actions:

- The Non-Urgent alarm will be set active (AIS-S).
- AIS will be transmitted to the remote station by AIS-R.

4.2.4 E1 Clock Modes

4.2.4.1 Clock Sources

The following block diagram shows the possible clock sources for the LTU and the NTU (Note, that the external clock option is not available for the NTU!). The clock sources are intended to be references only and do not drive the DSL transmit section physically.

Data rate adaptation between the 2048kHz clock and the DSL transmit clock is achieved by stuffing / deleting bits in the DSL frames.

The E1 interface clock is never affected by the crystal controlled DSL clock.

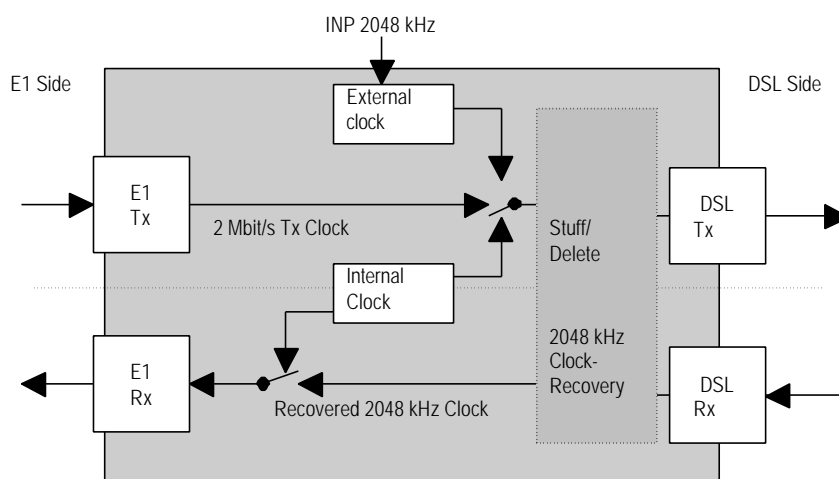

Figure 4-1: Clock Sources

Note: Signals towards the transceiver section are denoted as Tx and signals coming from the transceiver sections are denoted as Rx.

As long as the DSL link is not established, the internal clock oscillator is used as clock source.

The clock sources are automatically switched by the microcontroller, depending on the actual signal and clock status, which is updated every 100 ms.

The transmit clocks of the two E1 data directions are independent of each other. Both plesiochronous and synchronous operation modes are possible. Synchronous operation occurs when the E1 equipment at one end of the DSL link uses the receive clock as transmit clock, as shown below.

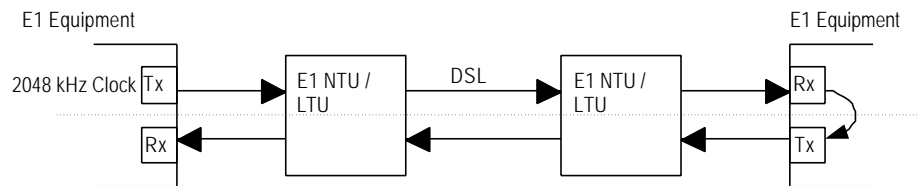

Figure 4-2: Synchronous Operation (=“Loop Timing”)

Warning: Do not configure the E1 interfaces at both ends to use the receive clock as transmit clock except if one DSL equipment is an LTU using the “External Clock” option. Otherwise there will be no defined clock.

4.2.4.2 External Clock Mode

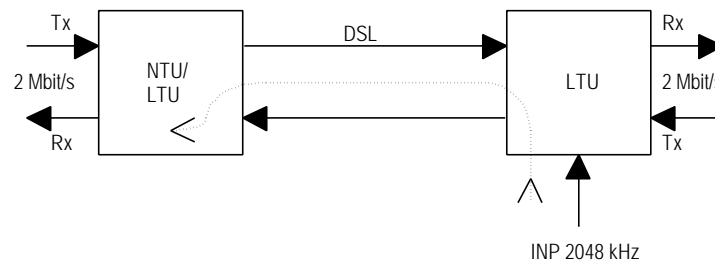

Figure 4-3: External Clock Mode

In “External Clock” mode, the 2048kHz input clock is fed directly in the LTU in case of the minirack or via the ACU clock input in case of the plug-in LTU. The external clock is used as the E1 reference clock.

If the “External Clock” option is enabled, the primary E1 clock source is the external clock. If no external clock is present at the 2048kHz clock input, the E1 transmit clock is used as the clock source. If no signal is received at the E1 port, then the internal clock is used as the clock source.

If the “External Clock” option is disabled, the primary E1 clock source is the 2Mbit/s transmit clock. If no signal is received at the E1 port, then the internal clock is used as the clock source.

The external clock is never used to drive the E1 Rx direction.

Note: There is neither an external clock input nor a clock output on the NTU side. The E1 Tx clock rate is defined by the incoming E1 Tx data rate. The Rx clock rate is the recovered Tx clock rate of the remote side or the local internal clock. The primary E1 Rx clock source is the recovered 2048kHz clock.

4.3 ISDN PRA Interface

In PRA mode, the DSL modem offers the functions of an ISDN PRA NT1, a LT or a combination of the functions of NT1 and LT. This makes it possible to use two setups:

- The slave modem at the customer premises is configured as NT1, the master modem at the central office is configured as LT.
- The slave modem at the customer premises is configured as NT1 & LT. Direct access to the exchange is established by a bit-transparent DSL-Link. All data, including time slot 0, from the exchange must be transmitted transparently (also time slot 0) to the PRA-NTU, therefore the DSL equipment providing the line termination is E1 working in transparent mode (see Figure 4-4).

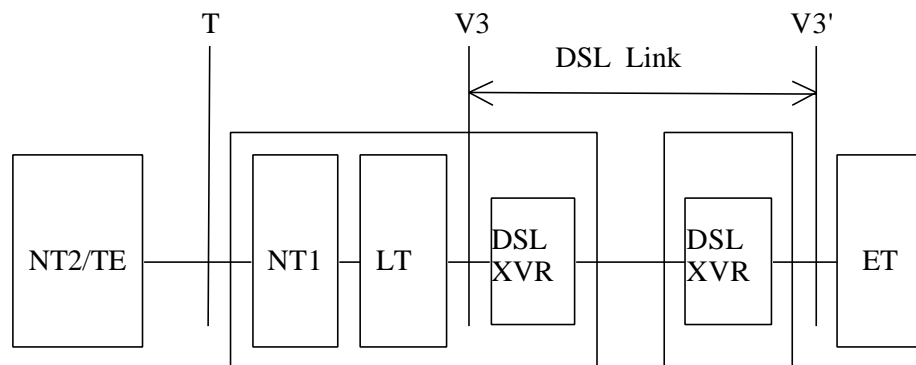

Figure 4-4: Reference Points of the PRA

Normally, the PRA-digital section (NT1 and LT) is configured as a digital link with CRC processing in the NT1 (option 2, according to I.604). However, also the other subscriber access options described in I.604 Annex A, can be configured. One of the DSL system units must be configured as master and the other as slave. Normally, the LTU (or the NTU, respectively) at the exchange is configured as the master on the DSL link, and the PRA-NTU as slave.

The equipment described above provides an access digital section for ISDN primary rate at 2048kbit/s. The 120Ω port (or optionally the 75Ω In/Out BNC) is the user/network-interface for primary rate access, which is denoted as T reference point in ISDN terminology. The equipment at the user side of the T reference point, which may be TE1, TA or NT2, is termed TE or NT2 in the normative references. Therefore, it is denoted as NT2/TE in this document. The interface towards the exchange, which will be abbreviated ET in the following, is the V3 reference point.

4.3.1 PRA Mode

The modem can work as NT1, LT or NT1 and LT combined.

4.3.2 CRC4 Processing Options

In addition to the usual PRA operation with CRC4 processing in both directions, the PRA interface also offers other modes of operation. Following ITU-T Rec. I.604 Annex A, three subscriber access options for a digital link are supported. The PRA interface can be configured to work either as a digital link without CRC processing (option 1), a digital link with CRC processing in the NT1 (option 2) or a digital link with CRC monitoring only in the NT1 (option 4). A digital link with CRC processing in the LT and NT1 is possible by using an DSL link consisting of an NT1 and an LT, both configured with CRC processing on.

4.3.2.1 Digital Link without CRC Processing (Option 1)

In this mode, transparent transmission between the ET and the NT2/TE is possible. There is no CRC4 processing in the PRA-NTU; the CRC processing is only done in the ET and the NT2/TE.

When loss of incoming signal is detected on either side, AIS is transmitted at the opposite side.

The detection of events and the state information are still valid as in normal PRA operation mode (option 2).

Depending on the distribution of NT1 and LT functionality, two setups are possible for option 1:

- The master is E1 configured transparent, AIS-generation on and AIS-detection off; the slave is PRA NT1 & LT, CRC4 processing off.
- The master is PRA LT with CRC4 processing off, the slave is PRA NT1 with CRC4 processing off.

Note: For proper operation in Option 1, the equipment at the customer side (NT2) and at the central office side (ET) must be in CRC4 framed mode.

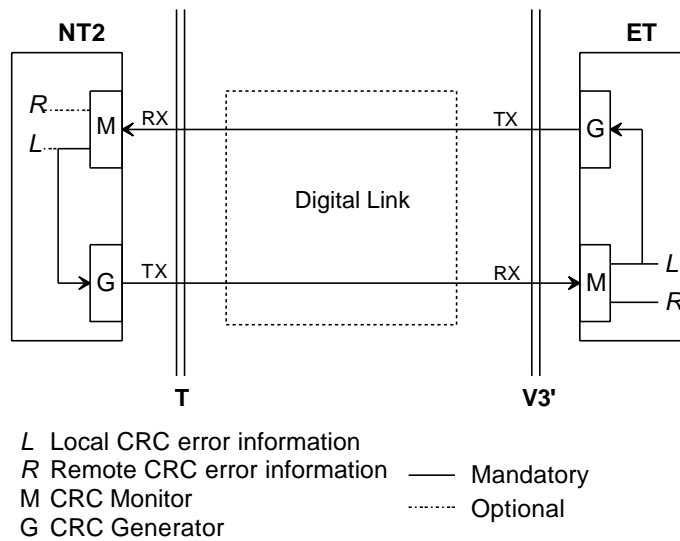

Figure 4-5: Digital Link without CRC Processing

4.3.2.2 Digital Link with CRC Processing in the NT1 (Option 2)

This is the usual PRA operating mode as described in ETS 300 233 and ITU-T Rec. G.962 Annex B. The PRA interface is intended to be used in this mode.

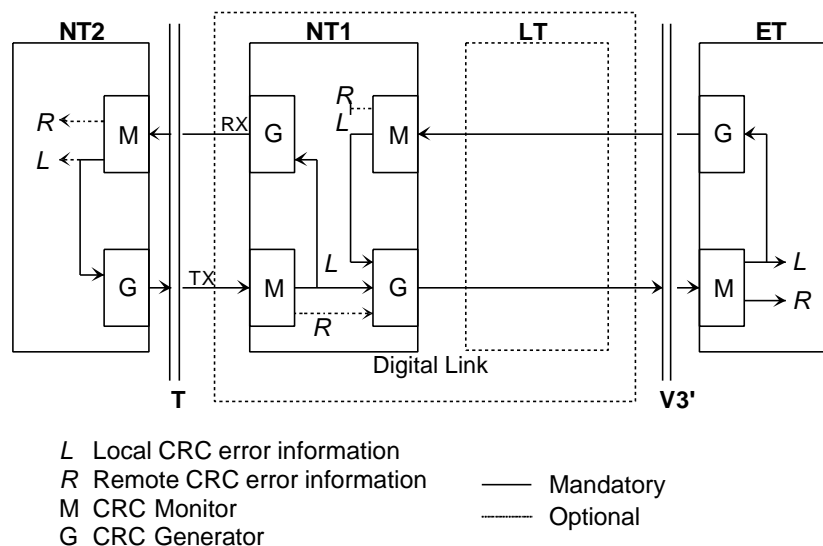

Figure 4-6: Digital Link with CRC Processing in the NT1

CRC4 is generated towards the NT2/TE and towards the ET and monitored at both sides of the NT1. When a block with a CRC4 error is received from the NT2/TE, CRC4 error

information is transmitted towards the NT2/TE (via E-bits) and optionally towards the ET (via Sa6-bits). When a block with a CRC4 error is received from the ET, error information is transmitted towards the ET (via E-bits). CRC4 errors detected at the T reference point of the NT2/TE are reported to the NT1 (via E-bits) and optionally towards the ET (via Sa6-bits). CRC4 errors detected at the V3 reference point of the ET are reported to the NT1 (via E-bits). Loopback 1 and 2 control facilities and monitoring of defect conditions are implemented according to ETS 300 233.

Depending on the distribution of NT1 and LT functionality, two setups are possible for option 2:

- The master is E1 configured transparent, AIS-generation on and AIS-detection off; the slave is PRA NT1 & LT, CRC4 processing on.
- The master is PRA LT with CRC4 monitoring on, the slave is PRA NT1 with CRC4 processing on.

4.3.2.3 Digital Link with CRC Processing in the LT and NT1 (Option 3)

In this mode, the NT1 behaves like in option 2. The LT is not transparent, but has CRC4 generation and monitoring in both directions. This option is not possible when using combined NT1 & LT mode, the setup for option 3 is:

- The master is PRA LT with CRC4 processing on, the slave is PRA NT1 with CRC4 processing on.

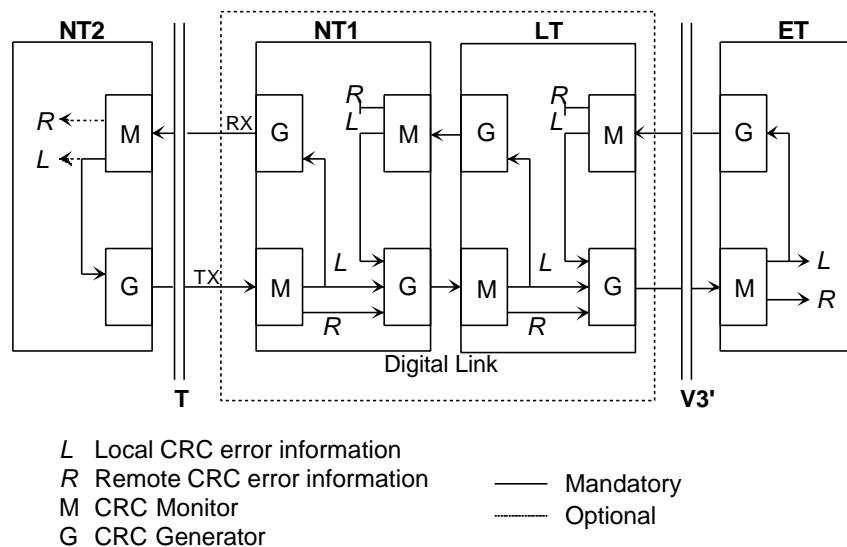

Figure 4-7: Digital Link with CRC Processing in the LT and NT1

4.3.2.4 Digital Link with CRC Monitoring in the NT1 (Option 4)

CRC4 multiframe alignment and checksum words are not regenerated in both directions, i.e. data will be transmitted without changes in both directions. However, blocks with CRC4 errors received from the NT2/TE and the ET will be detected and monitored by the G.826 performance management functions of the NTU monitor.

When loss of signal or loss of frame alignment is detected at either side, AIS is transmitted at the opposite side.

The detection of events and the state information are still valid as in normal PRA operation mode (option 4).

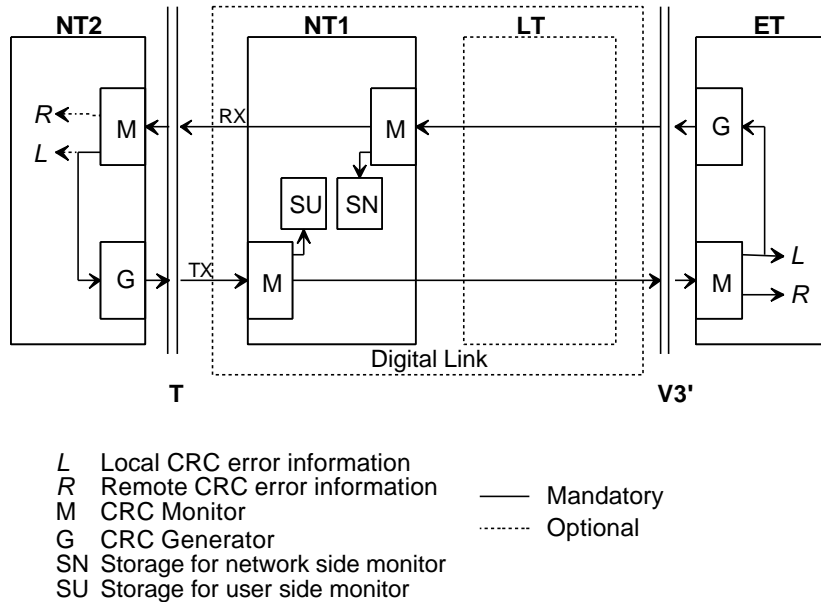

Figure 4-8: Digital Link with CRC Monitoring in the NT1

Depending on the distribution of NT1 and LT functionality, two setups are possible for option 1:

- The master is E1 configured transparent, AIS-generation on and AIS-detection off; the slave is PRA NT1 & LT, CRC4 monitoring on.
- The master is PRA LT with CRC4 processing off, the slave is PRA NT1 with CRC4 monitoring on.

4.3.3 Generation of CRC4 Error Notifications to the ET

For enhanced maintenance capabilities, CRC4 errors detected at the interface at the T reference point may optionally be reported to the ET (see ETS 300 233 section 8.3 and table 4 of ITU-T Rec. G.962 section B.5 and table B.2). CRC blocks in error detected at the T reference point of the NT1 as well as CRC error indications received from the NT2/TE in the E-bits are reported to the ET by using the Sa6-bits. An ET applying asynchronous detection of the Sa6-bits (no synchronization of the Sa6-bits to the sub-multiframe) will misinterpret such CRC4 error reports from the NT1 with other defect indications, e.g. loss of power at NT1 or FC4. Therefore, this Sa6-bits indication can be disabled.

- If the CRC4 error notification in Sa6 is enabled, Sa6=0001 indicates an E-bit received from the NT2/TE, Sa6=0010 indicates a CRC4 error detected at the T reference point of the NT1, and Sa6=0011 indicates the simultaneous occurrence of both errors.
- If disabled, Sa6 is always 0000 in normal operation state.

As sending of Sa-bits requires regeneration of the CRC4 frames in the NT1, this option is only activated when option 2 (Digital link with CRC processing in the NT1) is selected.

4.4 n x 64kbit/s Interface

This chapter describes the configuration options and alarms related to the n x 64kbit/s user interface.

4.4.1 Features

- The n x 64kbit/s interface is software-configurable between V.35, V.36 and X.21.
- The bit rate can be selected in steps of 64kbit/s from 64kbit/s up to 2048kbit/s (n x 64kbit/s, n=1...32)
- Independent receive and transmit clocks for V.35 and V.36.
- Codirectional (from equipment connected to n x 64kbit/s port) and contradirectional (clock generated by internal reference or from receive clock recovery) transmit clocks are possible.
- Detection for loss of clock and clock rate mismatch in codirectional clock mode.
- Standard SubD25 connector (ISO 2110 for V.35, RS-530 for V.36, proprietary for X.21) for DCE operation, other connectors (ISO 2593 for V.35, ISO 4902 for V.36, ISO 4903 for X.21) both for operation as DCE or DTE are available by means of adapter cables.
- Loop 1 and Loop 2 supported, for V.35 and V.36 they can also be controlled by circuits 140 (RL) and 141 (LL), according to V.54.
- Support for byte timing (circuit B) in X.21 mode.
- Mixed mode n x 64kbit/s - E1, n x 64kbit/s - Ethernet possible.

4.4.2 Configuration

4.4.2.1 Time Slot Mapping

4.4.2.1.1 Terminology

In the following, time slot numbers 0 to 31 denote the positions where E1 time slots 0 to 31 are mapped to the DSL frame according to TS 101 135.

The n x 64kbit/s bandwidth is the bit rate which is available for the n x 64kbit/s interface

- for equipment with both E1 and n x 64kbit/s interface: the n x 64kbit/s bit rate,
- for equipment with configurable DSL line rate and no E1 interface: the DSL line rate - 16kbit/s,
- for equipment with fixed DSL rate and no E1 interface: $32 \times 64\text{kbit/s}$.

The E1 bandwidth is the bit rate which is available for the E1 interface,

- for equipment with both E1 and n x 64kbit/s interface: the E1 bit rate,

- for equipment with configurable DSL line rate and no $n \times 64\text{ kbit/s}$ interface: the DSL line rate - 16 kbit/s ,
- for equipment with fixed DSL rate and no $n \times 64\text{ kbit/s}$ interface: $32 \times 64\text{ kbit/s}$.

The mapping of the $n \times 64\text{ kbit/s}$ data to the time slots 0 to 31 depends on the $n \times 64\text{ kbit/s}$ bit rate configured and $n \times 64\text{ kbit/s}$ bandwidth. The mapping of the E1 data to the time slots 0 to 31 depends on the E1 bandwidth.

4.4.2.1.2 $n \times 64\text{ kbit/s}$ Time Slot Mapping

With an $n \times 64\text{ kbit/s}$ bandwidth of $32 \times 64\text{ kbit/s}$, the time slots are filled as follows (depending on the $n \times 64\text{ kbit/s}$ bit rate n):

- for $n \leq 15$, time slots 1 to n are filled with $n \times 64\text{ kbit/s}$; the unused time slots are filled with all ones data,
- for $16 \leq n \leq 30$, time slots 1 to 15 and 17 to $n+1$ are filled with $n \times 64\text{ kbit/s}$ data (time slot 16 is skipped); the unused time slots are filled with all ones data,
- for $n = 31$, time slots 1 to 31 are filled with $n \times 64\text{ kbit/s}$ data,
- for $n = 32$, time slots 0 to 31 are filled with $n \times 64\text{ kbit/s}$ data.

4.4.2.1.3 E1 Time Slot Mapping

A mixed mode connection is a link between a modem using an E1 / PRA interface and a modem using an $n \times 64\text{ kbit/s}$ or Ethernet interface. The $n \times 64\text{ kbit/s}$ / Ethernet data is available in n E1 time slots:

- for $n \leq 15$, time slots 1 to n ,
- for $16 \leq n \leq 30$, time slots 1 to 15, 17 to $n+1$,
- for $n = 31$, time slots 1 to 31,
- for $n = 32$, time slots 0 to 31.

4.4.2.2 User Interface Type

The interface mode can be set to V.35, V.36 or X.21.

4.4.2.3 Bit Rate

The bit rate can be selected in the range of 64 kbit/s up to 2048 kbit/s in steps of 64 kbit/s ($n = 1..32$).

4.4.2.4 Clock Mode

Previous versions of $n \times 64\text{ kbit/s}$ interfaces from Schmid Telecommunication used the same clock to receive and to transmit data. A phase difference was allowed, but the clock frequencies had to be nominally equal. This led to a few restrictions when configuring the $n \times 64\text{ kbit/s}$ port. Note, that these restrictions still apply when using old equipment together with new equipment. In that case, follow the configuration instructions in the previous manual.

For V.35 and V.36, the receive and the transmit clock are independent. The receive clock is always the recovered remote clock. The clock mode configuration applies only to the transmit clock. For X.21, there is only one clock (circuit S) to receive and transmit, the

clock mode determines the source of that single clock; however, in the codirectional n x 64 port clock mode, X is used as a codirectional transmit clock and S is used only as receive clock. In the following section the clock which can be selected by the clock mode is denoted as “transmit clock”.

The clock mode determines in most cases, whether the transmit clock is codirectional (it has the same direction as the transmit data, i.e. it is an input signal) or contradirectional (it has the contrary direction of the transmit data. i.e. it is an output signal).

These clock modes are possible:

- n x 64 port: The transmit clock is the codirectional clock coming from the equipment connected to the n x 64kbit/s port (circuit 113, X).
- E1 port: The transmit clock is generated from the transmit clock used at the E1 port. The 2048kHz E1 clock is fractionally synthesized to the bitrate configured and available at the contradirectional transmit clock output (circuit 114).
- Internal: The transmit clock is generated from the internal reference clock (contradirectional, circuit 114).
- Remote: The transmit clock is the recovered remote clock, i.e. the same clock as the receive clock (115) at the V.35 and V.36 interface (contradirectional, circuit 114).

The clock mode to be used depends on the individual network configuration:

- n x 64kbit/s - n x 64kbit/s connection: First, it should be checked whether the equipment connected to the n x 64kbit/s port uses a transmit clock output or input. In the first case, the codirectional nx64 port mode can be used. In the latter case, one of the contradirectional clock modes should be used. The internal clock mode should be suitable in most cases, the remote clock can be used if the receive and transmit clocks have to be equal.

As the contradirectional X.21 clock modes use only one clock, these configurations are possible: n x 64 Port - n x 64 Port, n x 64 Port - Remote, Internal - Remote.

- n x 64kbit/s - E1 connection: The clock mode can be selected as in the previous case.
- n x 64kbit/s - Ethernet connection: Ethernet modems have the same restrictions as prior n x 64kbit/s equipment: The receive and the transmit clocks have to be equal. Therefore the network can have only one system clock. The Ethernet NTU will provide the clock when it is configured as master. Then the n x 64kbit/s clock mode has to be remote. When the Ethernet NTU is slave and the n x 64kbit/s NTU/LTU master, the clock must be determined by the n x 64kbit/s equipment, i.e. its clock mode must be internal or local port.

It is recommended to have at least one clock reference. So one should not use remote clock mode at both ends. You should not choose remote clock mode either if the remote modem is E1 and the E1 equipment connected to the remote E1 port uses loop timing (i.e. it uses the received clock as transmit clock).

4.4.2.5 Clock Direction

In most cases, the clock direction depends on the clock mode and cannot be configured. An exception is E1 port clock mode: In this case codirectional or contradirectional clock direction can be configured. However, in almost all cases, a contradirectional clock should be used. A codirectional clock can only be used, if it has the same reference as the E1 transmit signal (i.e. its rate is nominally equal to n/32 of the E1 rate).

A clock direction configuration is also possible for last-generation NTUs which are equipped with two n x 64kbit/s interfaces working in local port 1 or 2 clock mode. Then it can be selected whether the other port uses also a codirectional clock (both codirectional clocks must have the same reference).

4.4.2.6 V.54 Loops and Loop Control

As the X.21 interface provides only the control interchange circuits C and I, most of the features described afterwards are only applicable for V.35 and V.36, but not for X.21.

4.4.2.6.1 Normal Handshake Operation

When no loopback is established, the control circuits perform this handshake protocol:

- 105 (RTS Request to send; X.21: C): Input from DTE. For X.21, C = OFF will cause a DTR alarm.
- 106 (CTS Ready for sending; X.21: I): Is set ON when an DSL connection is established and 105 = ON is detected.
- 107 (DSR Data set ready): Is set ON when an DSL connection is established.
- 108 (DTR Data terminal ready): Input from DTE. For V.35 and V.36, 108 = OFF will cause a DTR alarm.
- 109 (RLSD Data channel received line signal detector): Is set ON when an DSL connection is established.
- 140 (RL Loopback / Maintenance test): Input from DTE; will be set OFF in normal mode.
- 141 (LL Local loopback): Input from DTE; will be set OFF in normal mode.
- 142 (TM Test indicator): Is set OFF in normal mode.

4.4.2.6.2 Supported V.54 Loops

ITU-T recommendation V.54 defines four test loops. Loops 2 and 3 correspond to DSL loopbacks 2 and 1. The interchange circuits are set in the following way:

- V.54 Loop 3
Local loop established in the DCE, i.e. DSL loopback 1 in an n x 64kbit/s NTU/LTU. These output interchange circuits are set: 107 = ON and 142 = ON
- V.54 Loop 2
Loop in remote DCE, i.e. DSL loopback 2 in the remote (slave) NTU/LTU.
These output interchange circuits are set:
 - Master: 107 = ON and 142 = ON
 - Slave: 104 (received data) = 1, 106 = OFF, 107 = OFF, 109 = OFF and 142 = ON.

4.4.2.6.3 Automatic Loop Control through the DTE/DCE Interface

Automatic control through the interface is achieved by using circuits 140 and 141:

- 140 = ON and 141 = OFF \Rightarrow V.54 loop 2 (DSL loopback 2)
- 140 = OFF and 141 = ON \Rightarrow V.54 loop 3 (DSL loopback 1)

This automatic loop control can be switched on/off using the “V54LOOPS” configuration option.

The interface on the user side can be a DTE or a DCE. To connect them to the interface port, the V.35 DTE or V.35 DCE cable must be used.

4.4.2.7 Byte Timing

In the X.21 mode, the byte timing circuit B according to X.24 can be activated (configuration option “BYTETIMING”). As the circuits B (byte timing) and X (codirectional transmit clock) share the same pins on the 15-pin ISO 4903 connector, separate cables have to be used for these cases.

4.5 TMN Interface (Minirack LTU only)

The Telecommunication Management Network (TMN) is connecting the Management Center (MC), Agent Elements (AEs) and Modems. Towards the MC the network is based on a X.25 or a LAN connection. Between AE and modems this network is established by means of a serial, asynchronous bus with differential (balanced) line transmission according to TIA/EIA-485 standard. Independent if the bus is set-up by a 2- or 4-wire connection the bus communication between Common Management Unit (CMU) and the Line Termination Units (LTUs) is always operating in half-duplex mode. The CMU is representing the Agent Element and is working as bus master on the EIA-485 side. The LTUs are representing the modem and work as bus slaves on the EIA-485 side.

4.5.1 TIA/EIA-485 4-wire Bus

The default TMN communication between **Minirack** versions of CMU and LTU is using a 4-wire transmission with different pairs for receive and transmit direction.

This bus system requires a crossing of RX and TX signals between CMU and LTU.

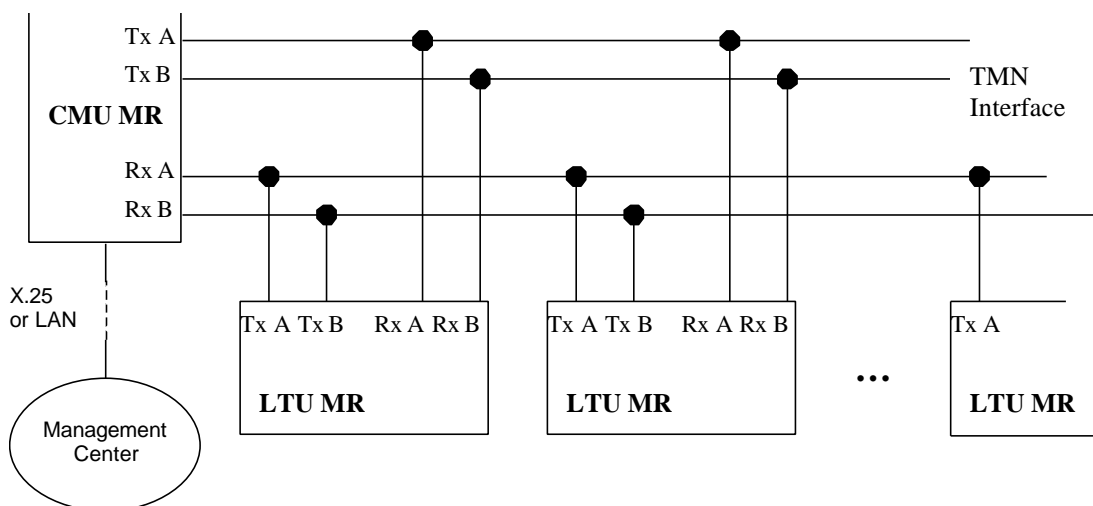

Figure 4-9: TMN Bus 4-Wire Connection for Minirack Units

4.5.2 TIA/EIA-485 2-wire Bus

TMN communication can be established via an EIA-485 2-wire connection as well. In this case no crossing of signals between CMU and LTU is required.

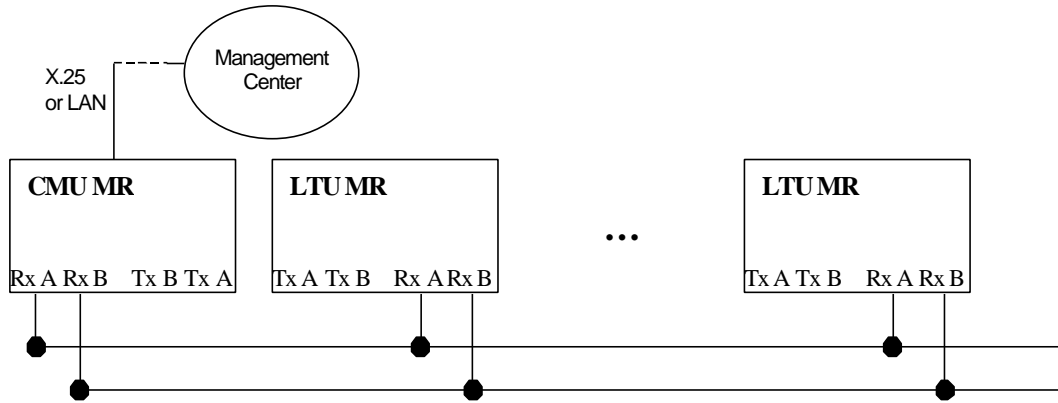

Figure 4-10: TMN Bus 2-Wire Connection for Minirack Units

A Plug-in version of the CMU is available as well. Due to the fact maximum 32 units can be connected to an EIA-485 bus, 1 CMU is able to handle more than the 12 LTUs located in one subrack. The extension of the TMN bus in the backplane towards a second subrack is realized by means of the Alarm Control Unit (ACU).

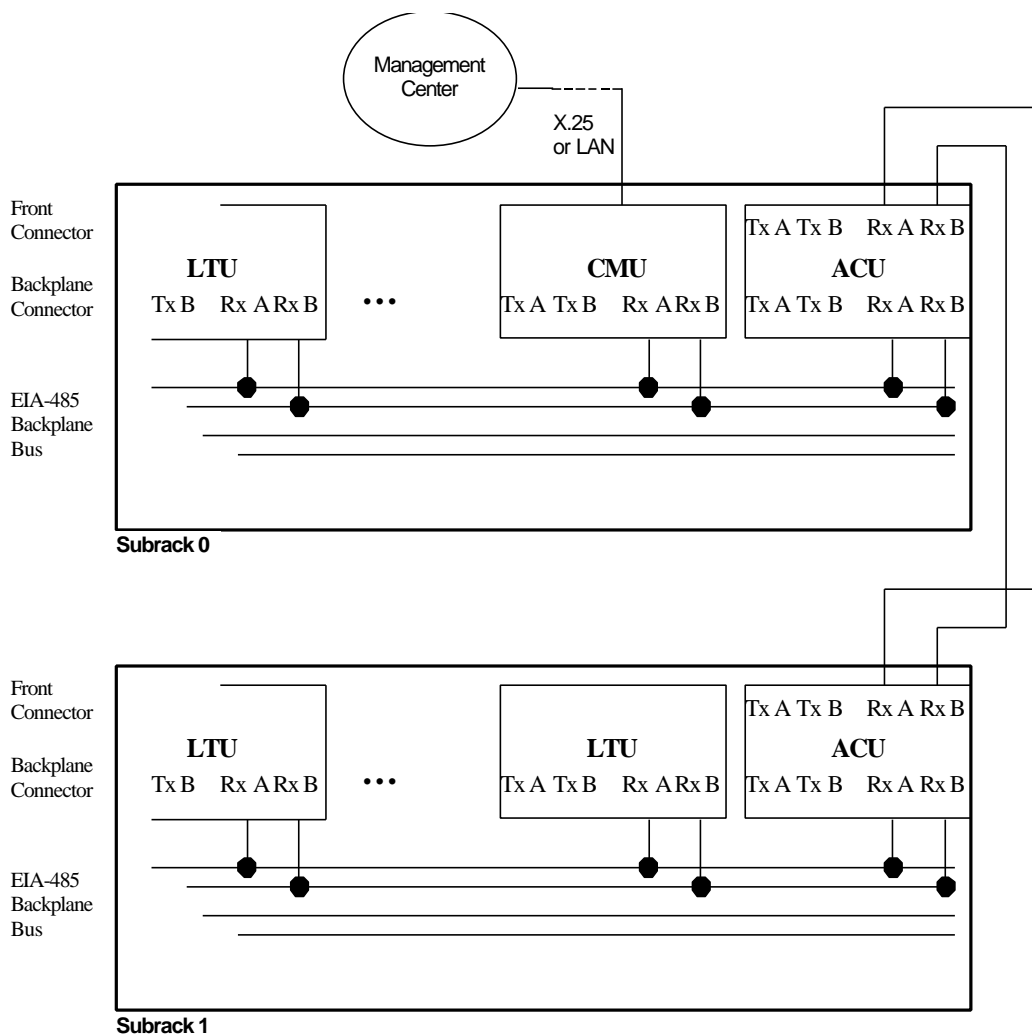

Figure 4-11: TMN Bus 2-Wire Connection for Plug-in Units

Limitation: Plug-in versions of CMU, ACU and LTU support 2-wire connection only

In case of a single subrack configuration and if no external alarm indications have to be controlled, an ACU is not needed in the subrack. But direct access for configuration of LTUs via the monitor interface on a local craft terminal is not possible without an ACU.

4.5.3 TIA/EIA-485 Bus Termination

In order to achieve highly reliable connections with a minimum of reflections, a termination with 120Ω is required at both ends of the bus by the TIA/EIA-485 standard.

A bus termination is not imperative when transmission is applied over short distances ($< 1m$) and with signalling rates ...200 kbps.

The TMN bus communication is running with a signalling rate of 5 kbps. Due to this fact a termination is required only if TMN bus is extended via cable over long distances and especially if different reference ground levels are applied at both ends of the bus (different racks).

Plug-in versions of ACU and CMU offer jumpers to connect a simple 120 Ω parallel termination to both differential wire pairs of the TMN bus.

ACU Plug-in: Closing J4 and J5 will activate the termination.

CMU Plug-in: Closing jumper ST4 and ST5 will activate the termination.

More for reasons of avoiding excessive ground currents than for signal quality, the grounding configuration for the signal return path shown in Figure 4-12 is recommended for a TMN bus connections with different ground levels at both ends.

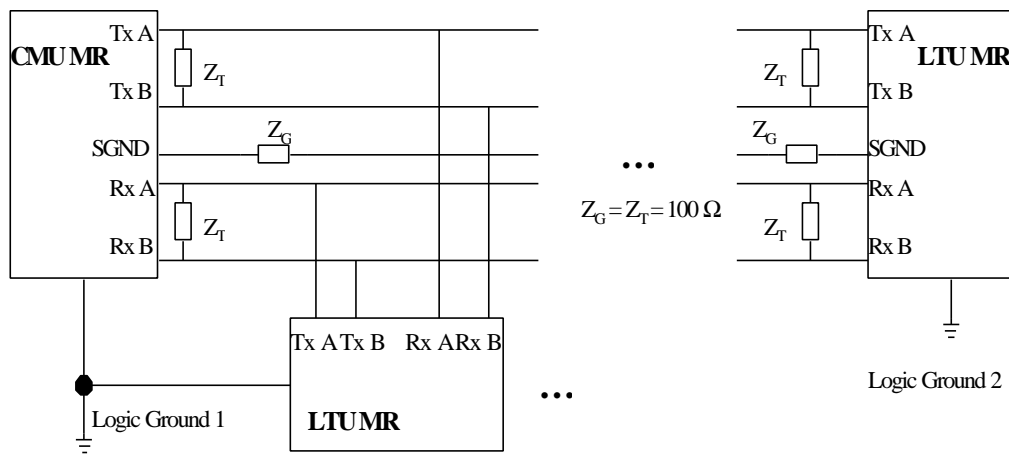

Figure 4-12: Termination for Long TMN Bus

5 Performance Monitoring

The transmission performance of a DSL link can be monitored in two different ways. The DSL signal quality is typically used during installation and maintenance procedures, whereas the G.826 error performance parameters are intended to be used for long term evaluation of an operating DSL link. Refer also to the “SQ” and “G826” monitor commands described in the “Monitor Operation” chapter.

5.1 Noise Margin

The Noise Margin (NM) provides *qualitative* performance information according to TS 101 135 of a specific loop and is an effective maintenance tool to determine inadequate or bad cable pairs.

A NM of 0dB, in presence of Gaussian noise would yield an expected Bit-Error-Ratio of 10^{-7} .

5.2 G.826 Performance Monitoring

The G.826 error performance parameters provide *quantitative* performance information of a specific loop. They are intended to be used for long term evaluation of operating DSL links.

The evaluation of the G.826 error performance parameters is based on CRC (Cyclic Redundancy Check) error detection: The estimation of a *bit-error rate* is not within the scope of the G.826 calculations.

5.2.1 DSL Interface

On the DSL side, six CRC6 check bits are generated per DSL frame for each channel and direction. For signaling detected block-errors in the return direction, the FEBE-bits are used. The DSL G.826 performance of the opposite unit is calculated according to these FEBE-bits.

CRC6 errors are used by the software to count the block-errors of the respective DSL channel and to evaluate its error performance according to ITU-T G.826.

The regenerator also monitors received DSL frames from the LTU (REG-R side) and from the NTU (REG-C side) using CRC6. Detected CRC errors are reported to both stations using the RRBE (errors detected at LTU side) and RCBE (errors detected at NTU side) bits. These bits are used to calculate the G.826 performance of the regenerator.

In case of severe impairments on the second section (REG - NTU), the G.826 performance of the first section is likely to be degraded due to the regenerator's strict coupling of the received and transmitted DSL frames. Whenever one of the regenerator's receivers recovers frame-alignment, the transmitter that passes on these HDSL frames will immediately adjust the frame start to the recovered frame-timing. As a result, a disturbed REG-NTU section will cause occasional LFAs at the LTU side and, as a consequence, degrade the LTU's G.826 performance (based on CRC6 and RRBE).

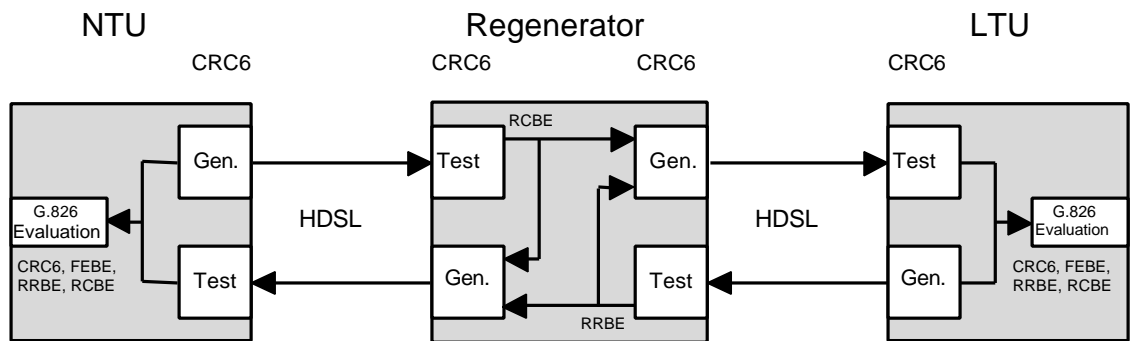

Figure 5-13: Regenerator G.826 Performance Evaluation

5.2.2 E1 Interface

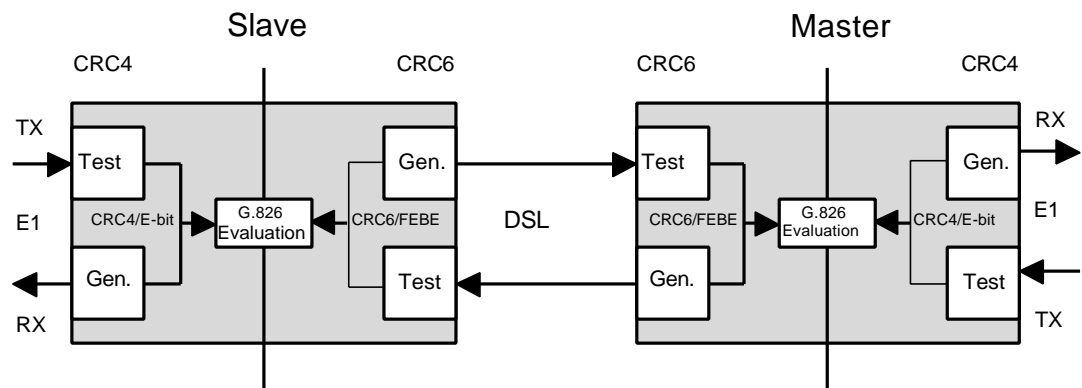

Figure 5-14: E1 G.826 Performance Evaluation

On the E1 side, four CRC4 check bits are generated per sub-multiframe (SMF) and compared with the corresponding CRC4 bits in the following SMF. If they do not match, the CRC4 error counter is incremented. The opposite station is informed of detected CRC4 errors by setting E-bits in the transmitted frames. At the same time, the E-Bits from the opposite station are counted and can be used for performance-monitoring.

For the E1 interface, calculations according to G.826 are only possible in framed mode with CRC4 option enabled. In framed mode with CRC4 option disabled only FAS-errors are detected.

5.2.3 ISDN PRA Interface

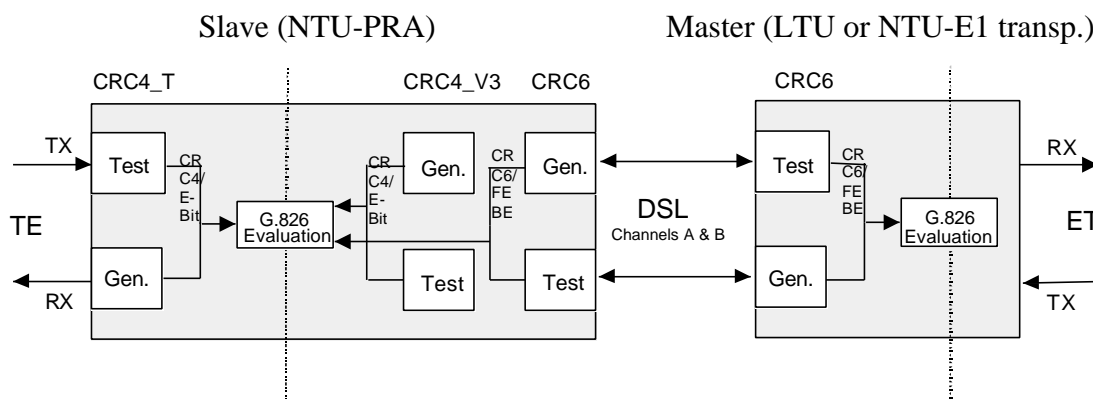

Figure 5-15: PRA G.826 Performance Evaluation

When the PRA interface is working with CRC4 processing or monitoring (options 2 and 4) four CRC4 check bits are generated per sub-multiframe (SMF) received from the ET and the NT2/TE and compared with the corresponding CRC4 bits in the following SMF. If they do not match, the corresponding CRC4 error counter is incremented. At the same time, the E-Bits from the ET and the NT2/TE are counted and can be used for performance-monitoring.

For the PRA interface, calculations according to G.826 are only possible when CRC4 processing or monitoring is selected.

6 Alarms

6.1 LEDs

The two LEDs 'Status Local' and 'Status Remote' are used to display normal operation condition and alarm condition. Each LED can be green, amber, or red according to the following table.

6.1.1 Status LEDs

Status	Local LED	Remote LED
Power failure	off	off
Hardware - / Software failure	blinking	off
Normal operation (Master mode)	green	green
Normal operation (Slave mode)	green	off
Non-urgent alarms(Local / remote)	amber	amber (off for slave)
Urgent alarms (Local / remote)	red	red (off for slave)
Regenerator alarm or Loopback (Master mode)	amber	red

6.1.2 Alarm Conditions

6.1.2.1 Local LED

An alarm condition is displayed with the Local LED if one of the following conditions occurs:

Urgent alarm (red):

- Hardware or software failure (blinking)
- Loss of signal / frame alignment on the DSL side, depending on the DSL operating mode:

DSL operating mode	Alarms
Normal	LOS/LFA-A or LOS/LFA-B
Fractional	LOS/LFA-A
Partial	LOS/LFA-A and LOS/LFA-B
Hot Standby	LOS/LFA-A and LOS/LFA-B

- DSL block-error-rate according G.826 $\geq 30\%$ (BER-H, BER-REG-H)
- LTU only: overcurrent detected in remote power feeding circuit (CLDET-A, CLDET-B)

Non-urgent alarm (amber):

- DSL block-error-rate according G.826 $> 15\%$ (BER-L)
- Either Loop 1, Loop 2, Analog Loopback, or the Regenerator Loopback is active (LOOP1, LOOP2, ALB, LOOPREG)
- Receiving regenerator alarm (REG-A, REG-B), indicating second section (REG-NTU) has not yet started and/or Regenerator Loopback is active (Master mode)
- Alarm cut off is activated (ACO)

E1 Interface:

- Loss of signal or frame alignment on the E1 side (LOS-S, LFA-S)
- Loss of external clock (EXT-LOC, in external clock mode only)
- Receiving AIS on E1 side (AIS-S)
- Excessive block error rate on E1 side (BER-S)

PRA Interface:

- Loss of signal at the T reference point (LOS-S)
- Loss of frame at the T reference point (LFA-S)
- Receiving AIS at the T reference point (AIS-S)
- Loss of frame at the V3 reference point (LFA-V3)
- Receiving AIS at the V3 reference point (AIS-V3)

n x 64kbit/s Interface:

- Loss of codirectional clock or clock rate mismatch (clock mode: n x 64 port) on the n x 64kbit/s side (LOC),
- Data Terminal Ready (DTR, circuit 108/2) on the n x 64kbit/s port is detected as 'OFF'. For X.21, the control-signal (C) is represented by DTR.
- The loops 1 and 2 can be controlled by the circuits 140 (RL) and 141 (LL), thus the alarms LOOP1 and LOOP2 can also be caused by the n x 64kbit/s interface

Displaying an urgent alarm has a higher priority than displaying a non-urgent one, i.e. an amber alarm will be “overwritten” by a red alarm.

6.1.2.2 Remote LED

The remote LED is an image of the local LED of the remote slave station (see previous LED-table for exceptions). When configured as “slave” no remote access is possible, so the remote LED is turned off.

6.2 Alarm Relays

6.2.1 LTU

There are two concepts for signaling the alarm status of the LTU in the subrack.

Each LTU has an open collector alarm output working on a common signaling line. The ACU2R gives consolidated alarm signals to the sum alarm relays “Urgent” and “Non-urgent”.

The alarm status is also analyzed by the ACU48R via the internal monitor bus to poll each of the possible 24 (=12 dual) LTUs within the subrack and to signal the alarm status to two alarm relays “Urgent” and “Non-urgent” specific for each LTU.

Under normal LTU power conditions the two output stages of each LTU are controlled by its microcontroller. In case of a power failure on an LTU, both the “Urgent” and “Non-urgent” alarms will be activated on the ACU. (The ACU generates an auxiliary +5 V_{DC} which is used to pull-up the open collector alarm output stages of the LTUs.)

6.2.1.1 Alarm Conditions

Urgent Alarm:

- At least one of the LTU – LEDs displays a red alarm
- Power failure of any one of the LTUs
- Power failure of the auxiliary +5V_{DC} auxiliary supply on the ACU
- Power failure of both –48V_{DC} supplies

Non-urgent Alarm:

- At least one of the LTU – LEDs displays an amber alarm and none of the LTU – LEDs displays a red alarm
- Power failure of any one of the LTUs
- Power failure of the auxiliary +5V_{DC} auxiliary supply on the ACU
- Power failure of one of the –48 V_{DC} supplies

Note: The E1 LTU/NTU must be configured as master and the n x 64kbit/s NTU as slave when the line rate is lower than 2064kbit/s.

6.2.2 NTU

The two alarm relays “Urgent” and “Non-urgent” are located on the NTU, the alarm contacts are available on the monitor connector.

6.2.2.1 Alarm Conditions

Urgent Alarm:

- At least one of the NTU - LEDs is red

Non-urgent Alarm:

- At least one of the NTU - LEDs is amber and none of the NTU - LEDs is red

Note: If alarm cut off is activated (ACO = on), the alarm relays are disabled.

7 Power Concept

7.1 LTU

7.1.1 Power and Grounding

Each plug-in LTU is fed via subrack backplane with (dual) $-48V_{DC}$ (referenced to $0V_{DC}$ of the exchange battery), whereas the minirack LTU is fed via an internal power supply unit. The LTU generates the used voltages onboard.

The ground reference of all voltages on the secondary side of the LTU's DC/DC-converter are tied to FPE (Functional Protective Earth).

Additionally, the plug-in LTU is fed over the backplane with an auxiliary $+5V_{DC}$ supply (referenced to ground) generated on the ACU. The only purpose of this voltage is to drive the alarm circuitry on each LTU, even in the case of a failure of the LTU's onboard DC/DC-converter.

In case of a failure of the LTU's onboard power supply, both LEDs on the front panel will be extinguished.

7.2 NTU

7.2.1 Power and Grounding

The ground of an NTU is typically floating when referenced to earth. If an NTU is equipped with an E1 or n x 64kbit/s user interface, the shields / signal ground of the cables are coupled to the ground of the NTU.

Powering of the NTU unit can be selected by a slide switch located on the rear side of the housing:

- Remote powering from the LTU over the DSL line or
- Local powering by an external AC/DC or DC/DC adapter

The position of the switch can be changed by means of a small screw driver. Before operating the switch, the DSL line connector and the mains adapter connector should be removed.

The supply voltage input is protected against reversal of polarity but **not fused**. Appropriate fusing has to be done externally. AC/DC adapters from SZ are recommended.

Caution: A $48V_{DC}$ battery supply must not be connected directly to the “AC/DC adapter” connector! High voltage transients from the DSL line may damage other equipment connected to the battery. A DC/DC converter with 4kV transient isolation voltage should be used in this case.

7.2.2 Power Failure Alarm

In case of a failure of the NTU's power supply, both LEDs will be extinguished.

The two DSL overhead bits *ps1* and *ps2* inform the remote LTU about the status of the NTU power supply. If the NTU is remotely powered, *ps1* is set to 1. If the NTU is locally powered, *ps2* is set to 1; if the supply voltage drops below $40.5V_{DC}$, *ps2* is set to 0 to inform the remote station about the dying local power supply of the NTU.

7.3 Remote Powering

Remote power feeding is supported. The remote NTU-R and the regenerator can be fully powered over the DSL twisted wire-pairs from the LTU-R. The remote power feeding concept has the following characteristics:

- Per pair remote feeding (no “phantom”-circuit)
- Cross-wiring tolerant
- Power feeding voltage within TNV-Limits (max. $120V_{DC}$)
- Independent current limiters on a per pair basis (microcontroller - controlled)
- Tolerant against micro-interruptions
- Automatic system restart after power failure
- Protection according to ITU-T Rec. K.20

The remote power voltage of $120V_{DC}$ is generated locally on each LTU-R and is referenced to earth. In case of overvoltage ($|U| > 120V_{DC}$), the unit is immediately shutdown within 100ms and can be reactivated only after an interruption of at least 500ms of its $-48V_{DC}$ supply / supplies. The LTU is able to feed up to $60mA_{DC}$ over each DSL pair.

Depending on the DC - loop resistance, the remote power voltage at the NTU-R may be far below $120V_{DC}$. The lowest acceptable voltage is approximately $65V_{DC}$.

The ability of providing remote power to the DSL line can be permanently switched off by placing the 4-fold R/L jumpers located on the PCB from position "RPWR A ON", "RPWR B ON",... into the “OFF” position. In this case, the DSL line interface is disconnected from the remote power circuitry and it behaves like the DSL interface of a NTU, i.e. it is floating.

Caution: If changing the remote powering condition the LTU must not be connected to the power supply. For the LTU in minirack the external power supply should be disconnected first before opening the cover!

Remote powering depends strongly on the power consumption of the NTU or REG (which in turn depends slightly on the supply voltage) as well as the loop resistance (wire diameter and cable length).

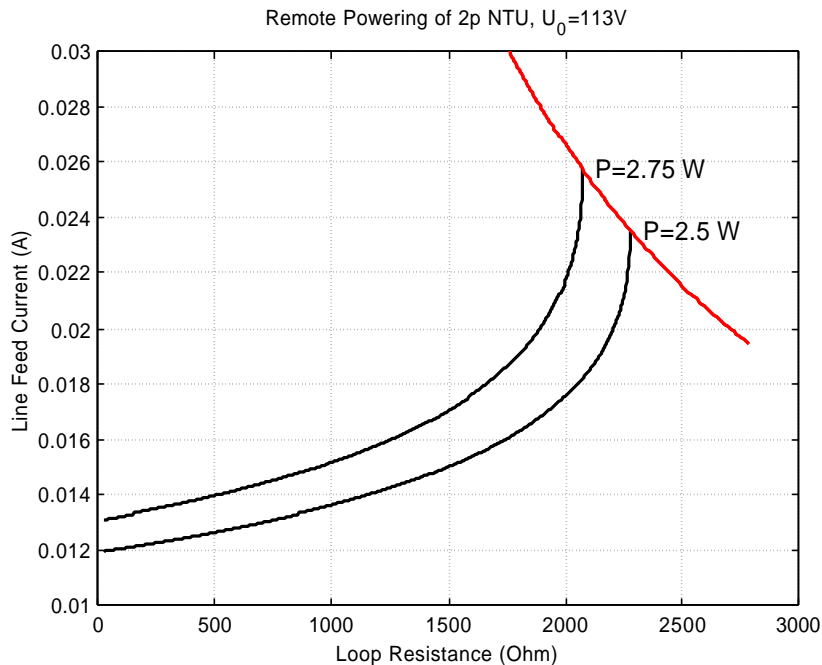

Figure 7-16: Line feed current vs loop resistance for different NTU power consumptions

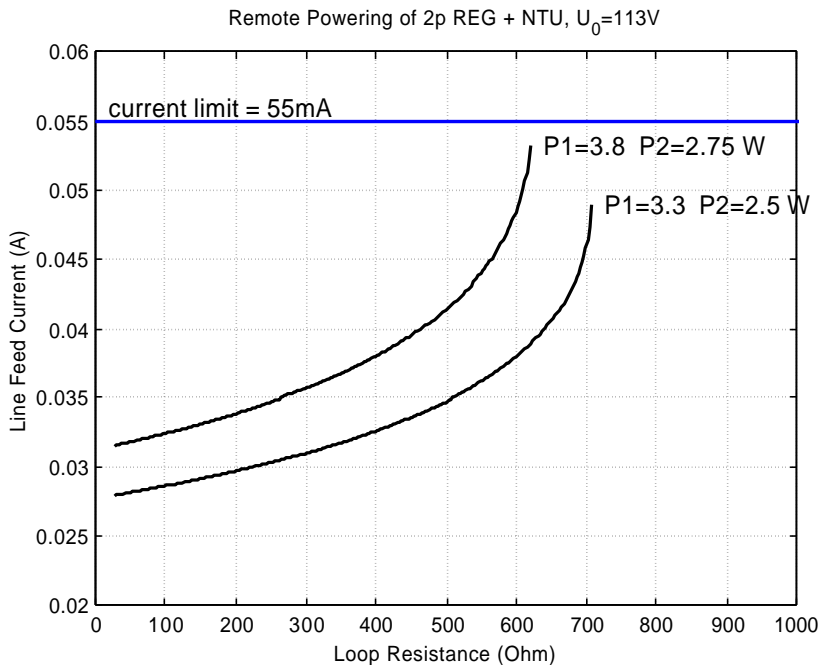

Figure 7-17: LTU powering one REG and one NTU: Line feed current vs loop resistance two different REG power consumptions

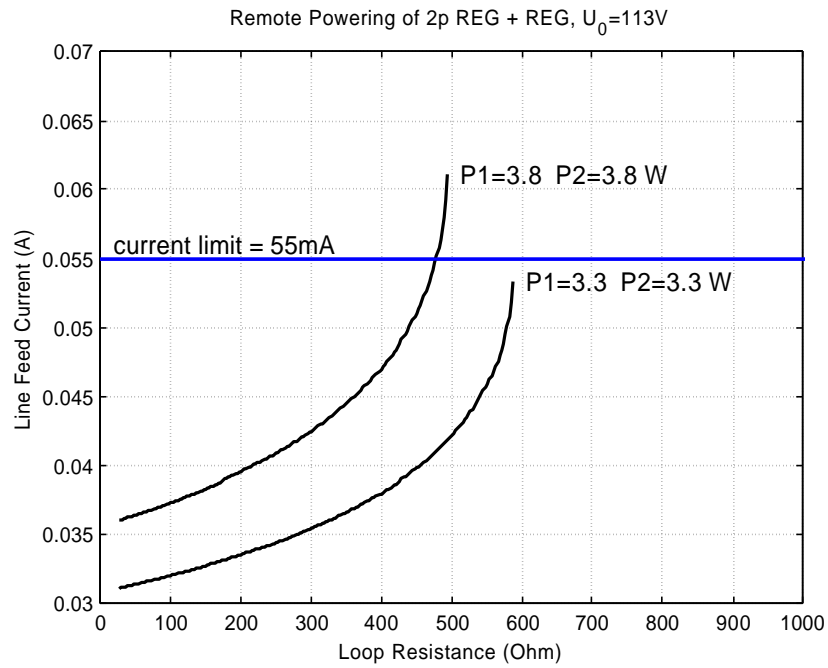

Figure 7-18: LTU powering two REGs: Line feed current vs loop resistance two different REG power consumptions

8 Monitor

8.1 General

The units can be connected to a terminal or a PC with a terminal emulation in order to monitor relevant events and to display additional information such as signal quality of the DSL link or the G.826 error performance parameters. In addition, full system configuration and fault localization can be done over the monitor interface.

The terminal for monitoring should be VT100 compatible and be configured as follows:

- 9600 baud, asynchronous
- 8 bits, no parity, one stop bit
- XON/XOFF enabled
- No new line on carriage return (i.e. no line feed on carriage return)

8.2 Addressing

8.2.1 LTU

There is a point / multipoint TTL-bus (9600 baud) on the subrack's backplane. The TTL to RS-232 level conversion is done on the ACU where the monitor connector is located.

In order to re-enable communication of LTUs occasionally left in XOFF state, it is recommended to start each session with Ctrl-Q (=XON) followed by an ECHO command.

At any one time, only one of the LTUs in the subrack can be logically connected to the monitor interface. The appropriate LTU interface is addressed (i.e. selected) according to its physical position in the subrack, starting with the leftmost slot number 01 and ascending rightwards to number 12. If one LTU supports a second interface, it may be addressed by adding 12 to the address of the first interface.

To select the first interface on the LTU in slot number *SN*, just type “%*SN*” at the terminal, even in the case it does not show any prompt. (e.g. to select the LTU in slot 01, type “%01”). To select the second interface (optional) in the same slot number, just type “%(*SN*+12)” at the terminal.

Single LTU Interface Addressing Scheme

Unit	LTU	LTU	LTU	LTU	LTU	LTU	LTU	LTU	LTU	LTU	LTU	LTU	ACU	PSB
First Interface Address	01	02	03	04	05	06	07	08	09	10	11	12	ACU	

Subrack

Dual LTU Interface Addressing Scheme

Unit	LTU	LTU	LTU	LTU	LTU	LTU	LTU	LTU	LTU	LTU	LTU	LTU	ACU	PSB
First Interface Address	01	02	03	04	05	06	07	08	09	10	11	12	ACU	
Second Interface Address	13	14	15	16	17	18	19	20	21	22	23	24		

Subrack

Figure 8-19: LTU Interface Addressing Scheme

To see which units in a rack are available, you can use the “ECHO” command. Each present unit will respond with its associated slot number (%SN).

The response could be : %01 %03 %08 %10 %11 %12 %15

Note: Each command must be terminated by a carriage return.

8.2.2 LTU Minirack

For Minirack versions of the LTU, the address number of the DSL interface can be set manually by monitor commands in the Configuration Management (CM) menu. After power-up of a Minirack LTU the local monitor main menu appears always with the first DSL system activated (behaviour like a NTU).

Address numbers in range 1-127 can be set independently to the different DSL systems of a LTU.

8.2.3 NTU

There is no need of addressing for a point-to-point connection.

8.3 Structure and Organization

The structure and organization of the monitor menu is adapted to ITU-T M.3400 for TMN with its five sub-sets.

Sub-set	Short-form
Performance management	PM
Fault and maintenance management	FMM
Configuration management	CM
Accounting management	AM
Security management	SM

Since accounting management is not supported, AM is not in the monitor's main menu.

Watson II
E1 Monitor V4.2

Copyright (C) 95,98,99 by Schmid Telecom AG Zuerich, Switzerland

```

+-----+
|           |
|   Main Menu   |
|           |
+-----+

```

1. Performance management (PM)
2. Fault and maintenance management (FMM)
3. Configuration management (CM)
4. Security management (SM)
5. Exit

LTU_04> Select [1..5]:

To select the desired sub-menu, type the appropriate number.

Notes:

The “Exit” command, number 5, is only available on the LTU. To address another LTU, type “%SN”.

8.3.1 Performance Management PM

The G.826 error performance parameters are intended to be used for long term evaluation of operating DSL links (see chapter “Performance Monitoring”).

03:33:10 Performance management activated
type <M> to return to MAIN, or <H> for HELP information

Type <H> and the monitor lists all available commands in the performance sub-menu:

```
LTU_04_PM> H
~~~~~
G826          Display HDSL G.826 parameter
G826 C        Display HDSL G.826 parameter continuously
G826 E1       Display local E1 G.826 parameter
G826 E1 C     Display local E1 G.826 parameter continuously
G826 REGn     Display regenerator G.826 parameter
G826 REGn C   Display regenerator G.826 parameter continuously
RESETG826    Reset G.826 error performance parameter
M(AIN)       Return to main menu
~~~~~
LTU_04_PM>
```

8.3.1.1 G826 Command

The G826 command displays the ITU-T G.826 error performance parameters on the DSL line side of the local and remote DSL unit:

```
LTU_04_PM> G826
~~~~~
G.826 Error Performance :   CRC6 A   CRC6 B   FEBE A   FEBE B
~~~~~
Errored blocks          : 00000000 00000000 00000000 00000000
Errored seconds         : 00000000 00000000 00000000 00000000
Severely errored seconds : 00000000 00000000 00000000 00000000
ESR [%]                :      0.00      0.00      0.00      0.00
SESR [%]               :      0.00      0.00      0.00      0.00
BBER [%]               :      0.00      0.00      0.00      0.00
Available time         : 00624483 00624483 00624483 00624483
Unavailable time       : 00000024 00000024 00000024 00000024
~~~~~
LTU_04_PM>
```

Definitions:

1. CRC6: Cyclic redundancy check indicating errored blocks are being received on the local DSL side.
2. FEBE: Far end block error indicating errored blocks are being received on the remote DSL side.
3. Errored block (EB): A block in which one or more bits are in error.
4. Errored seconds (ES): A one second period with one or more errored blocks. SES defined below is a subset of ES.
5. Severely errored second (SES): A one second period which contains $\geq 30\%$ errored blocks.
6. Background block error (BBE): An errored block not occurring as part of an SES.

7. Errored second ratio (ESR): The ratio of ES to total seconds in available time during a fixed measurement interval.
8. Severely errored second ratio SESR: The ratio of SES to total seconds in available time during a fixed measurement interval.
9. Background block error ratio (BBER): The ratio of errored blocks to total blocks during a fixed measurement interval, excluding all blocks during SES and unavailable time.

Options:

C: Updates the G.826 parameters continuously

REGn: The G826 REGn command displays the ITU-T G.826 error performance parameter of the nth regenerator:

```
LTU_04_PM> G826 REG1
```

```
~~~~~
G.826 Error Performance :   RRBE1 A   RRBE1 B   RCBE1 A   RCBE1 B
~~~~~
Errored Blocks          :   00000000   00000000   00000000   00000000
Errored seconds         :   00000000   00000000   00000000   00000000
Severely errored seconds :   00000000   00000000   00000000   00000000
ESR [%]                 :         0.00         0.00         0.00         0.00
SESR [%]                :         0.00         0.00         0.00         0.00
BBER [%]                :         0.00         0.00         0.00         0.00
Available time          :   00000221   00000221   00000206   00000206
Unavailable time        :   00000027   00000027   00000042   00000042
~~~~~
```

```
LTU_04_PM>
```

1. RRBE_n: nth Regenerator remote block errored indicating error blocks are being received on the REG-R (LTU) side of the regenerator.
2. RCBE_n: nth Regenerator central block errored indicating error blocks are being received on the REG-C (NTU) side of the regenerator.

E1: The G826 E1 command displays the ITU-T G.826 error performance parameters on the E1 2Mbit/s side. This command is only available if framed mode is enabled.

If CRC4 mode is on, the following parameters are displayed:

```
LTU_04_PM> G826 E1
```

```
~~~~~
G.826 Error Performance :   CRC4       E-Bit
~~~~~
Errored Blocks          :   00000000   00000000
Errored seconds         :   00000000   00000000
Severely errored seconds :   00000000   00000000
ESR [%]                 :         0.00         0.00
SESR [%]                :         0.00         0.00
BBER [%]                :         0.00         0.00
Available time          :   00524129   00524129
Unavailable time        :   00000024   00000024
~~~~~
```

```
LTU_04_PM>
```

If CRC4 mode is off, the following parameters are displayed:

```

LTU_04_PM> G826 E1
~~~~~
G.826 Error Performance : FAS
~~~~~
Errored blocks          : 00000000
Errored seconds        : 00000000
Severely errored seconds : 00000000
ESR [%]                : 0.00
SESR [%]               : 0.00
BBER [%]               : 0.00
Available time         : 00009841
Unavailable time       : 00000024
~~~~~
LTU_04_PM>

```

Definitions:

1. CRC4: Cyclic redundancy check indicating errored sub-multiframes received on the local 2Mbit/s E1 side.
2. E-bit: CRC-4 indication bit denoting received errored sub-multiframes on the 2Mbit/s E1 side.
3. FAS: Errored Frame Alignment Signal received on the 2Mbit/s E1 side. The criteria for severely errored seconds (SES) is 28 FAS-Errors per second (in accordance to G.821).

In PRA mode, the G826 E1 command displays the ITU-T G.826 error performance parameters on the PRA 2Mbit/s:

```

LTU_04_PM> G826 E1
~~~~~
G.826 Error Performance : CRC4_T   E-Bit_T   CRC4_V3   E-Bit_V3
~~~~~
Errored Blocks          : 00000000  00000000  00000000  00000000
Errored seconds        : 00000000  00000000  00000000  00000000
Severely errored seconds : 00000000  00000000  00000000  00000000
ESR [%]                : 0.00      0.00      0.00      0.00
SESR [%]               : 0.00      0.00      0.00      0.00
BBER [%]               : 0.00      0.00      0.00      0.00
Available time         : 00524129  00524129  00524107  00524107
Unavailable time       : 00000024  00000024  00000046  00000046
~~~~~
LTU_04_PM>

```

Definitions:

1. CRC4_T: Cyclic redundancy check indicating errored sub-multiframes received at the NT1 side of the T reference.
2. E-Bit_T: CRC-4 indication bit indicating received errored sub-multiframes at the NT2/TE side of the T reference point.
3. CRC4_V3: Cyclic redundancy check indicating errored sub-multiframes received at the NT1 side of the V3 reference point.

4. E-Bit_V3: CRC-4 indication bit indicating received errored sub-multiframes at the ET side of the V3 reference point.

Note: The G826 E1 command is only available if option 2 (CRC4 processing) or option 4 (CRC4 monitoring) is selected in the configuration.

8.3.1.2 RESETG826 Command

The RESETG826 command sets the G.826 error performance parameters back to zero.

```
LTU_04_PM> RESETG826
04:35:30 G.826 error performance parameter reset
LTU_04_PM>
```

8.3.2 Fault and Maintenance Management FMM

```
04:41:20 Fault and maintenance management activated
          type <M> to return to MAIN, or <H> for HELP information
```

Type <H> and the monitor lists all available commands in the fault and maintenance sub-menu:

```
LTU_04_FMM> H
~~~~~
SQ                Turn HDSL signal quality trace on/off
SQ REGn          Turn regenerator signal quality trace on/off
STARTUP          Turn HDSL transceiver startup trace on/off
STATUS           Display local system status
STATUS R         Display remote system status
STATUS REGn      Display regenerator status
ALARM            Display local alarm status
ALARM R          Display remote alarm status
ALARM T          Turn alarm trace on/off
ACO [ON,OFF]     Activate / deactivate alarm cutoff
LOOP1 [ON,OFF]   Activate / deactivate local loopback
LOOP2 [ON,OFF]   Activate / deactivate remote loopback
LOOPREGn [ON,OFF] Activate / deactivate regenerator loopback
STARTAL          Start analog loopback
STOPAL           Stop analog loopback
TRACETIME [1..20] Change trace time (1..20 seconds)
RESET            Reset system
RESET R          Reset remote station
M(AIN)           Return to main menu
~~~~~
LTU_04_FMM>
```

8.3.2.1 SQ Command

The SQ command allows the user to turn the signal quality trace on and off:

```
LTU_04_FMM> SQ
04:53:30 HDSL signal quality trace on
04:53:30 HDSL noise margin: local A: --.- B: --.- / remote A: --.- B: --.- dB
04:54:30 HDSL noise margin: local A:+19.5 B:+19.5 / remote A:+19.5 B:+19.5 dB
```

```
04:55:30 HDSL noise margin: local A:+19.5 B:+19.5 / remote A:+19.0 B:+19.5 dB
LTU_04_FMM> SQ
04:56:30 HDSL signal quality trace off
LTU_04_FMM>
```

Note: If configured as master, both local and remote signal quality (signal quality at remote station) are reported; if configured as slave, only the local signal quality is reported. The master periodically reads the signal quality from the remote station via EOC. If no valid signal quality value was able to be communicated from the slave to the master since the last trace output, "--." will appear instead of the signal quality value.

8.3.2.2 SQ REGn Command

The SQ REGn command allows the user to toggle the signal quality trace of the nth regenerator on and off:

```
LTU_04_FMM> SQ REG1
05:07:40 regenerator (1) signal quality trace on
05:07:40 REG1 noise margin: REG-R A: --.- B: --.- / REG-C A: --.- B: --.- dB
05:08:40 REG1 noise margin: REG-R A:+20.0 B:+19.5 / REG-C A:+19.0 B:+19.0 dB
05:09:40 REG1 noise margin: REG-R A:+19.5 B:+19.5 / REG-C A:+19.5 B:+19.0 dB
05:10:40 REG1 noise margin: REG-R A:+19.5 B:+19.5 / REG-C A:+19.5 B:+19.5 dB
05:11:40 REG1 noise margin: REG-R A:+19.0 B:+19.0 / REG-C A:+19.5 B:+19.0 dB
LTU_04_FMM> SQ REG1
05:11:70 regenerator (1) signal quality trace off
LTU_04_FMM>
```

Note: This command is available on LTU-R only. It periodically reads the signal quality from the regenerator via EOC. If no valid signal quality value was communicated from the regenerator to the master since the last trace output, "--." will appear instead of a signal quality value. Also, the activation of the regenerator loopback will force the REG-C values to appear as "--."

8.3.2.3 STARTUP Command

The STARTUP command allows the user to turn the startup trace on and off, in order to observe the LTU and NTU activation state diagram transitions. The activation state diagram transitions are conforming to ETSI TS 101 135. Note that in case of a regenerated DSL link, no activation state diagram transitions for the regenerator-NTU link can be monitored.

```
LTU_04_FMM> STARTUP
00:03:60 HDSL transceiver startup trace on
00:03:60 A - INACTIVE      : transmit SILENT
00:03:60 B - INACTIVE      : transmit SILENT
00:03:80 A - ACTIVATE_1   : transmit S0
00:03:80 B - ACTIVATE_1   : transmit S0
00:05:80 A - ACTIVATE_2   : signal detected
00:05:80 B - ACTIVATE_2   : signal detected
00:15:90 A - ACTIVATE_3   : transmit S1
00:15:90 B - ACTIVATE_3   : transmit S1
00:20:00 A - ACTIVATE_4   : transmit S1
```



```
00:20:00 B - ACTIVATE_4 : transmit S1
00:24:10 A - ACTIVATE_5 : final transceiver mode
00:24:10 B - ACTIVATE_5 : final transceiver mode
00:24:30 A - ACTIVE_RX : receive ready
00:24:30 B - ACTIVE_RX : receive ready
00:24:50 A - ACTIVE_TX_RX : transmit/receive 2B1Q data
00:24:50 B - ACTIVE_TX_RX : transmit/receive 2B1Q data
LTU_04_FMM>
```

8.3.2.4 STATUS Command

The STATUS command displays the actual system status:

```
LTU_04_FMM> STATUS
~~~~~
Local System Status                                     V4.2
~~~~~
SYNC-A: 02  PID-A: 01  LOSD-A: 00  HRP-A: 01  RPF-A: 01  RPS-A: 02
SYNC-B: 02  PID-B: 02  LOSD-B: 00  HRP-B: 01  RPF-B: 01  RPS-B: 02
MAIN   : A
~~~~~
LTU_04_FMM>
```

Definitions (shown for loop A; loop B similar):

Parameter	Status	Meaning
SYNC-A	00 02	Status of DSL synchronisation state machine of loop A according to ETSI TS 101 135. Out of Sync State In Sync State Note: This parameter does NOT suffice as an indication for an established DSL link.
PID-A	00 01 02	Pair Identification of Loop A according to ETSI TS 101 135. No PID information available Identification Pair No. 1 Identification Pair No. 2 Note: If PID-A is 02 and PID-B is 01 on the Slave side, then Pair A and Pair B between master and slave units are crossed. At the Master side, PID-A is always = 01 and PID-B = 02.
LOSD-A	-- 00 01	Status of LOSD-bit in DSL frame according to ETSI TS 101 135. No LOSD information available No signal at application interface of remote station (either LTU or NTU) Application interface signal of remote station is o.k.
HRP-A or NRA-A	-- 00 01	Status of HRP-bit in DSL frame according to ETSI TS 101 135. No HRP information available Regenerator present No regenerator present Number of Regenerators available.
RPF-A	00 01	Remote power feeding status. Remote power feeding on loop a switched off Remote power feeding on loop a switched on Note: If the LTU is configured with remote power on but RPF is off, the current limit detector has switched off the remote power feeding.

RPS-A		Status of ps1 and ps2 bit in DSL frame according to ETSI TS 101 135:
		ps1
	--	-
	00	0
	01	0
	02	1
	03	1
MAIN		DSL master loop
	A	Loop A
	B	Loop B
PRA (PRA mode only)		Current state of the digital section (DS) according to ETS 300 233 section 9.4 (only the states possible in NT1 & LT mode are displayed).
	00	NTU dying
	01	NTU dying & FV3/FC5
	02	NTU dying & FC4
	03	NTU dying & FC4 & FV3/FC5
	04	NTU dying & AIS
	05	NTU dying & AIS & FC4
	06	Normal function
	07	FC4
	08	FV3/FC5
	09	FV3/FC5 & FC4
	10	Loopback 1
	11	Loopback 1 & FC4
	12	Loopback 2
	13	Loopback 2 & FC4
	14	Loopback 1 & NTU dying
	15	Loopback 1 & NTU dying & FC4
	16	Loopback 2 & NTU dying
	17	Loopback 2 & NTU dying & FC4
18	AIS	
19	AIS & FC4	

Note: With an LTU-L, the RPF and RPS will always display 00.

Options:

R Displays the status of the remote station (supported by master only)

8.3.2.5 STATUS REGn Command

This command is only available on the LTU-R and reads the status of the nth regenerator over EOC.

```
LTU_04_FMM> STATUS REG1
05:50:10 reading status from regenerator (1)
LTU_04_FMM>
```

```
~~~~~
Regenerator Status (1)
```

V1.3

```

~~~~~
SYNC-RA: 02  SYNC-CA: 02  SQ-RA:+19.5  SQ-CA:+19.0
SYNC-RB: 02  SYNC-CB: 02  SQ-RB:+19.0  SQ-CB:+19.0
~~~~~

```

LTU_04_FMM>

Definitions (shown for loop A; loop B similar):

Parameter	Status	Meaning
SYNC-RA	00 02	Status of DSL synchronisation state machine of loop A at REG-R (LTU) side of regenerator according to ETSI TS 101 135. Out of Sync State In Sync State Note: This parameter does NOT suffice as an indication for an established DSL link.
SYNC-CA		Status of DSL synchronisation state machine of loop A at REG-C (NTU) side of regenerator, state coding as above.
SQ-RA		Signal quality of loop A at REG-R (LTU) side of regenerator [dB].
SQ-CA		Signal quality of loop A at REG-C (NTU) side of regenerator [dB].

Note: This command is available on the LTU-R only.

During regenerator loopback, the status of SYNC-CA and SYNC-CB shows '02' due to the loopback location inside the regenerator.

8.3.2.6 ALARM Command

The ALARM command displays the actual alarm status:

```
LTU_04_FMM> ALARM
```

```
~~~~~
Local Alarm Status
~~~~~
```

```

LOS-S: on   LOS/LFA-A: off  BER-H: off  LOOP1: off  CLDET-A: off
LFA-S: off  LOS/LFA-B: off  BER-L: off  LOOP2: off  CLDET-B: off
AIS-S: off  EXT-LOC  : off  AIS-R: on   ACO  : off
BER-S: off                                ALB  : off
~~~~~

```

```
Regenerator Alarm Status
~~~~~
```

```
REG1-A: off  REG1-B: off  BER-REG1: off  LOOPREG1: off
~~~~~
```

LTU_04_FMM>

Options:

- R Displays the status of the remote station (supported by master only)
- T Turns alarm trace on / off

Definitions:

LOS-S:	Loss of signal at subscriber (E1) side
LFA-S:	Loss of frame alignment at subscriber (E1) side
AIS-S:	AIS (Alarm Indication Signal) detected at subscriber (E1) side
BER-S:	Excessive Block Error Rate on subscriber side If CRC4 enabled : BER-S = on if more than 805 CRC4 Errors per second. If CRC4 disabled : BER-S = on if more than 28 FAS Errors per second.
EXT-LOC:	Loss of external clock
LFA-V3	Loss of frame alignment at V3-reference point (PRA mode)
AIS-V3	Alarm indication signal at V3-reference point (PRA mode)
LOS/LFA-A	Loss of signal or frame alignment at DSL loop A
LOS/LFA-B:	Loss of signal or frame alignment at DSL loop B
BER-REG-H:	DSL block error rate at regenerator according to G.826 $\geq 30\%$
BER-REG-L:	DSL block error rate at regenerator according to G.826 $> 15\%$
BER-H:	DSL block-error-rate according G.826 $\geq 30\%$
BER-L:	DSL block-error-rate according G.826 $> 15\%$
AIS-R:	Alarm indication from remote station
LOOP1:	DSL test loop 1 active
LOOP2:	DSL test loop 2 active
ACO:	Alarm cutoff
ALB:	Analog loopback
CLDET-A:	Current limit detection at loop A
CLDET-B:	Current limit detection at loop B
REG-A:	Alarm indication from regenerator at loop A or regenerator loopback active
REG-B:	Alarm indication from regenerator at loop B or regenerator loopback active
LOOPREG:	Regenerator loopback active

8.3.2.7 ACO Command

The ACO (Alarm Cut Off) command enables or disables the alarm relays. When ACO is 'on', all alarms are disabled and the alarm-relays are inactive. The local alarm LED signalizes a non-urgent alarm.

```
LTU_04_FMM> ACO ON
11:03:10 alarm cutoff activated
LTU_04_FMM> ACO OFF
11:11:70 alarm cutoff deactivated
```

8.3.2.8 LOOP1 Command

The LOOP1 command starts the local loopback:

```
LTU_04_FMM> LOOP1 ON
01:10:50 Loop 1 activated
LTU_04_FMM>
```

8.3.2.9 LOOP2 Command

The LOOP2 command starts the remote loopback:

```
LTU_04_FMM> LOOP2 ON
01:10:50 Loop 2 activated at remote station
LTU_04_FMM>
```

Note: The remote loopback is only possible from master side.

8.3.2.10 LOOPREGn Command

The LOOPREGn command starts the loopback in the nth regenerator:

```
LTU_01_FMM> LOOPREG1 ON
29:25:70 regenerator (1) loopback activated
LTU_01_FMM>
```

Note: This command is available on LTU-R only.

8.3.2.11 STARTAL Command

The STARTAL command starts the analog loopback:

```
LTU_04_FMM> STARTAL
01:04:00 analog loopback started
LTU_04_FMM>
```

Notes:

- The system unit must be configured as master for analog loopback operation.
- Detach the DSL line before starting the analog loopback. If the analog loopback is started while a remote station is attached to the DSL line, the remote station signal will interfere with the loopback signal, causing bit errors on the E1 side.
- To return to normal operation, restart the system either by power up or RESET command or use the STOPAL command.

8.3.2.12 STOPAL Command

The STOPAL command stops the analog loopback

```
LTU_04_FMM> STOPAL
02:04:00 analog loopback stopped
LTU_04_FMM>
```

8.3.2.13 TRACETIME Command

The TRACETIME command allows the user to change the trace display repetition time (range: 1 .. 20 sec):

```
LTU_04_FMM> TRACETIME 3
04:10:30 trace time changed to 03 sec
LTU_04_FMM> TRACETIME 1
04:20:10 trace time changed to 01 sec
LTU_04_FMM>
```

8.3.2.14 RESET Command

By typing RESET, the system unit will be restarted.

```
LTU_04_FMM> RESET
05:06:10 system reset
```

Option:

R Resets the remote station (supported by master only)

Note: On a Dual LTU both systems will be reset.

8.3.3 Configuration Management CM

```
02:26:00 Configuration management activated
Type <M> to return to MAIN, or <H> for HELP information
```

Type <H> and the monitor lists all available commands in the configuration sub-menu:

```
LTU_04_CM> H
~~~~~
CONFIG          Display local configuration
G704 [ON,OFF]   Set framed mode / transparent mode
CRC4 [ON,OFF]   Set CRC4 mode on/off
EBIT [ON,OFF]   Set automatic E-Bit insertion on/off
AISGEN [ON,OFF] Set AIS generation on/off
AISDET [ON,OFF] Set AIS detection on/off
EXTCLK [ON,OFF] Set external clock mode on/off
UIF [E1,PRA]    Set user interface type
POWER [ON,OFF]  Set remote powering on/off
MASTER [ON,OFF] Set HDSL master mode / slave mode
RESTART [ON,OFF] Set autorestart on/off
MODE [N,F,P,H]  Set HDSL operating mode
DEFAULT [0..2]  Set default configuration
REMOTE          Activate remote configuration
```

```
M(AIN) Return to main menu
~~~~~
LTU_04_CM>
```

Notes:

- The MASTER command is valid on the LTU-L only.
- The POWER command is valid on the LTU-R only.
- The UIF type command selects only equipped user interfaces.

8.3.3.1 CONFIG Command

The CONFIG command displays the configuration of the unit:

```
LTU_04_CM> CONFIG
~~~~~
Local Configuration Id : 2 Mbit/s G.703
~~~~~
2 Mbit/s
Framing      : ITU-T G.704
CRC4         : On
E-Bit Insertion : On
AIS Generation : On
AIS Detection  : On
External Clock : Disabled
HDSL
Master/Slave  : Master
Autorestart   : Enabled
Operating Mode : Normal
Channel A     : On
Channel B     : On
Remote Powering : On
~~~~~
LTU_04_CM>
```

Notes:

- To display the remote configuration (supported by master only) see REMOTE command in section “REMOTE Command”.
- After each configuration change, the new configuration is automatically displayed.
- The remote powering option will be displayed for the LTU-R only.

8.3.3.2 Configuration Commands

E1 Interface

G704:	Set framed mode / transparent mode.
CRC4:	Set CRC4 mode on / off.
EBIT:	Set automatic E-Bit insertion on / off.
AISGEN:	Set AIS generation on / off.
AISDET:	Set AIS detection on / off.

EXTCLK: Set external clock mode on / off.
UIF: Set the user interface type to E1 or PRA.

PRA Interface

PRA: Select the ISDN PRA functional entities of the modem:
OFF: No PRA function (transparent transmission)
NT1LT: Both NT1 and LT
LT: Only LT
NT1: Only NT1

CRC4: Set CRC4 processing option (Subscriber access option):
1: Digital Link without CRC4 Processing
2: Digital Link with CRC4 Processing
3: Option 3 is not available
4: Digital Link with CRC4 Monitoring

This configuration selects the subscriber access option of the whole digital section (NT1 and LT) only if PRA Mode NT1 & LT is selected. If NT1 and LT functions run on different modems, the CRC4 settings of both modems determine the access option (see description of PRA configuration options).

CRC4SA6: Set generation of CRC4 error notifications to the ET on / off (applies only to NT1).
UIF: Set the user interface type to E1 or PRA.

DSL Interface

POWER: Set remote powering on / off.
MASTER: Set DSL master mode / slave mode.

Note:

One unit must be configured as Master (DSL-side) and the other as Slave.

The master/slave configuration affects the whole unit, i.e. both modem of a Dual LTU.

RESTART: Set autorestart on / off.

MODE: Set HDSL operating mode: *Normal*, *Fractional*, *Partial*, *Hot Standby*.
Partial and Hot Standby operation are not available if remote power feeding is switched on.

8.3.3.3 DEFAULT Command

The DEFAULT command sets a default configuration. Three default-settings are available:

```
LTU_01_CM> DEFAULT 0
~~~~~
Local Configuration                               Id : 2 Mbit/s G.703
~~~~~
2 Mbit/s
Framing           : Transparent
CRC4              : --
E-Bit Insertion  : --
AIS Generation    : On
AIS Detection     : On
External Clock    : --
HDSL
Master/Slave     : Master
Autorestart      : Enabled
Operating Mode   : Normal
Channel A        : On
Channel B        : On
Remote Powering  : On
~~~~~
LTU_01_CM>
```

```
LTU_01_CM> DEFAULT 1
~~~~~
Local Configuration                               Id : 2 Mbit/s G.703
~~~~~
2 Mbit/s
Framing           : CCITT G.704
CRC4              : On
E-Bit Insertion  : On
AIS Generation    : On
AIS Detection     : On
External Clock    : Disabled
HDSL
Master/Slave     : Master
Autorestart      : Enabled
Operating Mode   : Normal
Channel A        : On
Channel B        : On
Remote Powering  : On
~~~~~
LTU_01_CM>
```

```
LTU_01_CM> DEFAULT 2
~~~~~
Local Configuration                               Id : 2 Mbit/s G.703
~~~~~
2 Mbit/s
  Framing           : Transparent
  CRC4              : --
  E-Bit Insertion  : --
  AIS Generation    : On
  AIS Detection     : Off
  External Clock    : --
HDSL
  Master/Slave     : Master
  Autorestart      : Enabled
  Operating Mode   : Normal
  Channel A        : On
  Channel B        : On
  Remote Powering  : On
~~~~~
LTU_01_CM>
```

In PRA mode, the default configurations give standard settings for each PRA mode (LT, NT1, NT1 & LT):

```
NTU_CM> DEFAULT 0
~~~~~
Local Configuration                               Id : ISDN PRA
~~~~~
PRA
  PRA Mode         : LT
  Access Option    : Monitoring on
  CRC4 Error->Sa6  : --
HDSL
  Master/Slave     : Slave
  Autorestart      : Enabled
  Operating Mode   : Normal
  Channel A        : On
  Channel B        : On
~~~~~
NTU_CM>
```

```

NTU_CM> DEFAULT 1
~~~~~
Local Configuration                               Id : ISDN PRA
~~~~~
PRA
  PRA Mode      : NT1
  Access Option : Processing on
  CRC4 Error->Sa6 : On
HDSL
  Master/Slave  : Slave
  Autorestart   : Enabled
  Operating Mode : Normal
  Channel A     : On
  Channel B     : On
~~~~~
NTU_CM>

```

```

NTU_CM> DEFAULT 2
~~~~~
Local Configuration                               Id : ISDN PRA
~~~~~
PRA
  PRA Mode      : NT1 & LT
  Access Option : Processing on
  CRC4 Error->Sa6 : On
HDSL
  Master/Slave  : Slave
  Autorestart   : Enabled
  Operating Mode : Normal
  Channel A     : On
  Channel B     : On
~~~~~
NTU_CM>

```

The factory setting can be loaded using the “DEFAULT 2” command. All DSL LTUs and NTUs are delivered with this configuration (LTUs as master, NTUs as slave).

Note: The Master/Slave and Remote Powering settings are not affected by the DEFAULT Command.

8.3.3.4 REMOTE Command

The REMOTE Command enables the remote configuration:

```

LTU_01_CM> REMOTE
11:32:50 remote configuration activated

```

Type <H> and the monitor lists all the available commands on the remote side:

```

LTU_01_CM_REMOTE> H
~~~~~
CONFIG          Display remote configuration
G704 [ON,OFF]   Set framed mode / transparent mode
CRC4 [ON,OFF]   Set CRC4 mode on/off
EBIT [ON,OFF]   Set automatic E-Bit insertion on/off

```

```

AISGEN [ON,OFF]      Set AIS generation on/off
AISDET [ON,OFF]     Set AIS detection on/off
UIF [E1,PRA]        Set user interface type
COPY                Copy local configuration to remote station
LOCAL              Return to local configuration
M(AIN)             Return to main menu
~~~~~
LTU_01_CM_REMOTE>

```

Note: The REMOTE command is only possible from master side.

8.3.3.5 COPY Command

The COPY command sets the remote configuration equal to the local.

8.3.3.6 LOCAL Command

The LOCAL command switches back to the local configuration:

8.3.4 Accounting Management AM

Accounting management is not supported.

8.3.5 Security Management SM

Security management is not supported.

8.4 Monitor Commands for the n x 64kbit/s Interface

This section deals only with n x 64kbit/s specific monitor commands.

8.4.1 Fault and Maintenance Management FMM

8.4.1.1 ALARM Command

```

NTU_FMM> ALARM
~~~~~
Local Alarm Status
~~~~~
DTR-1: on   LOS/LFA-A: on   BER-H: off  LOOP1: off
DTR-2: off  LOS/LFA-B: on   BER-L: off  LOOP2: off
LOC  : off                AIS-R: off  ACO  : off
~~~~~
NTU_FMM>

```

These alarms are related to the n x 64kbit/s interface:

DTR: Status of DTR (Data Terminal Ready) Handshake Signal. For X.21, the Control-signal (C) is represented by DTR.

DTR Signal is detected as 'ON' (Status: off)

DTR Signal is detected as 'OFF' (Status: on)

LOC: Loss Of Clock (When Local Clock mode is selected). LOC is also active when the incoming clock bit rate is not equal to the programmed bit rate (n).
Clock master present with correct bit rate (Status: off)
Clock master not present and/or bit rate mismatch (Status: on)

8.4.2 Configuration Management CM

```

NTU_CM> H
~~~~~
CONFIG          Display local configuration
BITRATE n1 n2   Set bitrate (n x 64 kbit/s) of Port 1 and 2:
                 n1,n2 = [0..32]
CLOCKMODE [0..3] Select clock source:
                 0=Port 1, 1=Port 2, 2=internal, 3=remote
CLOCKDIR dir1 dir2 Set clock direction of Port 1 and 2:
                 0=codir, 1=contradir
V54LOOPS [ON,OFF] Set V.54 loop control on/off
UIF [V35,V36,X21] Set user interface type
MASTER [ON,OFF] Set HDSL master mode / slave mode
RESTART [ON,OFF] Set autorestart on/off
DEFAULT [0..2] Set default configuration
M(AIN)          Return to main menu
~~~~~
NTU_CM>

```

8.4.2.1 CONFIG Command

The CONFIG command displays the configuration of the NTU unit (e.g. V.35):

```

NTU_CM> CONFIG
~~~~~
Local Configuration                               Id : nx64 kbit/s V.35
~~~~~
V.35
  Bitrate Port 1  : 32 x 64 = 02048 kbit/s
  Bitrate Port 2  : Off
  Clock Mode      : Remote
  Clockdir Port 1 : Contradirectional
  Clockdir Port 2 : Contradirectional
  V.54 Loops      : Disabled
HDSL
  Master/Slave    : Slave
  Autorestart     : Enabled
  Operating Mode  : Normal
  Channel A       : On
  Channel B       : On
~~~~~
NTU_CM>

```

8.4.2.2 BITRATE Command

Set bit rate (n x 64kbit/s) of Port 1 and Port 2: n1, n2 = [0..32]

To turn off the port the bit rate must be 0. Example n1= 32, n2 = 0.

The command for this example will be:

```
NTU_CM> BITRATE 32 0
```

8.4.2.3 CLOCKMODE Command

Select clock source: 0=Port 1, 1=Port 2, 2=internal, 3=remote.

8.4.2.4 CLOCKDIR Command

Set clock direction of Port 1 and 2: 0=codirectional, 1=contradirectional.

In most cases, the clock direction is implicitly set by the clock mode.

8.4.2.5 V54LOOPS Command

Select whether it is possible to switch loop 1 and 2 using the control circuits 140 (RL) and 141 (LL). This command is only available in V.35 and V.36 modes.

8.4.2.6 BYTETIMING Command

Select if circuit B for byte timing is used in X.21 mode. Note that to use the byte timing you need the appropriate cable and cannot use the codirectional transmit clock.

8.4.2.7 UIF Command

Select the interface type: V35 = V.35, V36 = V.36, X21 = X.21.

8.4.2.8 DEFAULT Command

The DEFAULT command sets a default configuration.

Three default settings are available for the n x 64kbit/s interface:

```
NTU_CM> DEFAULT 0
~~~~~
Local Configuration                               Id : nx64 kbit/s V.35
~~~~~
V.35
  Bitrate Port 1  : Off
  Bitrate Port 2  : Off
  Clock Mode      : Remote
  Clockdir Port 1 : Contradirectional
  Clockdir Port 2 : Contradirectional
  V.54 Loops      : Disabled
HDSL
  Master/Slave    : Slave
  Autorestart     : Enabled
  Operating Mode  : Normal
  Channel A       : On
  Channel B       : On
~~~~~
NTU_CM>
```

```
NTU_CM> DEFAULT 1
~~~~~
Local Configuration                               Id : nx64 kbit/s V.35
~~~~~
V.35
  Bitrate Port 1  : Off
  Bitrate Port 2  : Off
  Clock Mode      : Internal
  Clockdir Port 1 : Contradirectional
  Clockdir Port 2 : Contradirectional
  V.54 Loops      : Disabled
HDSL
  Master/Slave    : Slave
  Autorestart     : Enabled
  Operating Mode  : Normal
  Channel A       : On
  Channel B       : On
~~~~~
NTU_CM>
```

```
NTU_CM> DEFAULT 2
~~~~~
Local Configuration                               Id : nx64 kbit/s V.35
~~~~~
V.35
  Bitrate Port 1  : Off
  Bitrate Port 2  : Off
  Clock Mode      : Remote
  Clockdir Port 1 : Contradirectional
  Clockdir Port 2 : Contradirectional
  V.54 Loops      : Disabled
HDSL
  Master/Slave    : Slave
  Autorestart     : Enabled
  Operating Mode  : Normal
  Channel A       : On
  Channel B       : On
~~~~~
NTU_CM>
```

8.4.2.9 COPY Command

The COPY command sets the remote configuration equal to the local and is only available in the remote configuration menu.

8.5 Monitor Commands for LTU Minirack TMN Interface

For Minirack versions of the LTU, the address number of the DSL interface can be set manually by monitor commands in the Configuration Management (CM) menu. After power-up of a Minirack LTU always the local monitor main menu appears with the first DSL system activated (behaviour like a NTU).

Address numbers in range 1-127 can be set independently to the different DSL systems of a LTU.

The alternatives of running the TMN communication on a 2- or 4-wire bus can be selected in the CM menu as well. The list below shows the available commands in the Configuration Management menu of a Minirack LTU.

RESET command, DEFAULT command or power down has no influence on settings made for the TMN interface.

```
LTU_10_CM> H
~~~~~
CONFIG                Display local configuration
G704 [ON,OFF]         Set framed mode / transparent mode
CRC4 [ON,OFF]         Set CRC4 mode on/off
EBIT [ON,OFF]         Set automatic E-Bit insertion on/off
AISGEN [ON,OFF]       Set AIS generation on/off
AISDET [ON,OFF]       Set AIS detection on/off
EXTCLK [ON,OFF]       Set external clock mode on/off
POWER [ON,OFF]        Set remote powering on/off
RESTART [ON,OFF]      Set autorestart on/off
MODE [N,F,P,H]        Set HDSL operating mode
ADDRESS [1..127]      Set address
V11WIRES [2,4]        Set number of V.11 wires
DEFAULT [0..2]        Set default configuration
REMOTE                Activate remote configuration
M(AIN)                Return to main menu
~~~~~
LTU_10_CM>
```

8.5.1 ADDRESS Command

The ADDRESS command allows the user to assign an address number in the range between 1-127 to the current DSL interface of a Minirack LTU.

```
LTU_02_CM> ADDRESS 4
01:19:40    Address set to 04
~~~~~
Local Configuration                                Id : nx64 kbit/s V.35
~~~~~
V.35
  Bitrate Port 1  :  32 x 64 = 02048 kbit/s
                  :
                  :
                  :
HDSL
  Line Rate       :  02064 kbit/s
  Master/Slave    :  Master
  Autorestart     :  Enabled
  Remote Powering :  On
TMN
  Address         :  04
  V.11 wires no. :  04
~~~~~
LTU_04_CM>
```

Note: For a Dual LTU Minirack it is possible to assign a higher interface address number to DSL system A than to DSL system B.

For Plug-in LTUs the lowest interface number is always assigned to DSL system A and the pins with appropriate designation on the DSL connector of type RJ-45.

Note: Carefully note already used interface address numbers. No automatic protection against multiple LTUs assigned to the same interface address number can be applied in a set-up with several Minirack LTUs.

Two interfaces with same address number on the TMN bus will cause malfunction and the units will not be accessible by the TMN application SW.

Limitation: Both DSL systems of a Dual LTU can be addressed freely. But possible addresses are limited to the address ranges 01 - 12 and 33 - 44 by the Small Network Management Protocol (SNMP) used for communication with the Management Centre.

8.5.2 V11WIRES Command

The V11WIRES command allows to switch between 2- or 4-wire communication on the TMN interface (EIA-485 bus).

```
LTU_03_CM> V11WIRES 2
23:34:90    V.11 wires set to 02
~~~~~
Local Configuration                               Id : nx64 kbit/s V.35
~~~~~
V.35
  Bitrate Port 1  : 32 x 64 = 02048 kbit/s
                  .
                  .
                  .
HDSL
  Line Rate       : 02064 kbit/s
  Master/Slave    : Master
  Autorestart     : Enabled
  Remote Powering : On
TMN
  Address         : 03
  V.11 wires no. : 02
~~~~~
LTU_03_CM>
```

Note: 4-wire communication is recommended for Minirack configurations.

Note: 4-wire communication requires a crossing of Rx and TX signals between CMU and LTU. 2-wire communication uses only Rx A and Rx B wires without any crossing.

9 Front and Rear Panel Description

9.1 Tabletop NTU, Rear Panel

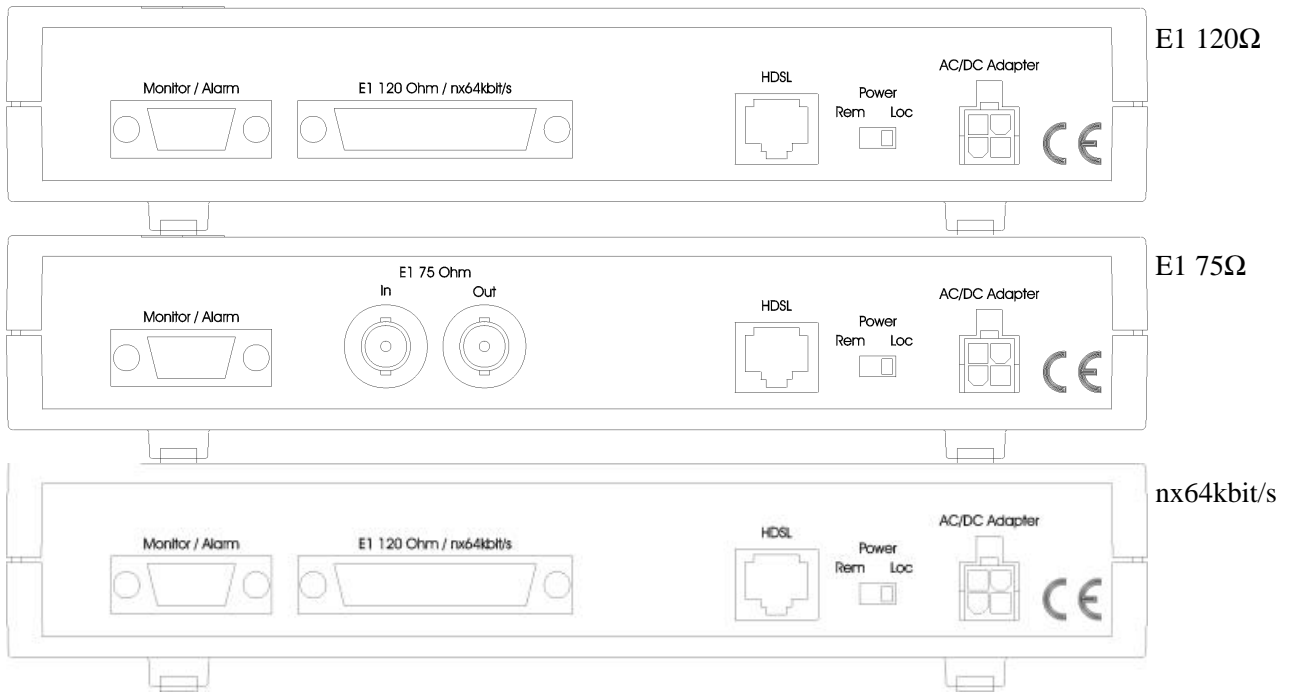

9.2 Minirack NTU, Front Panel

E1 120Ω

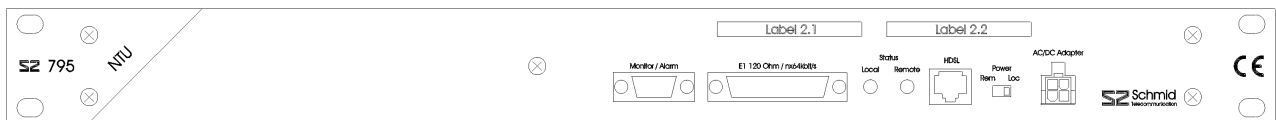

E1 75Ω

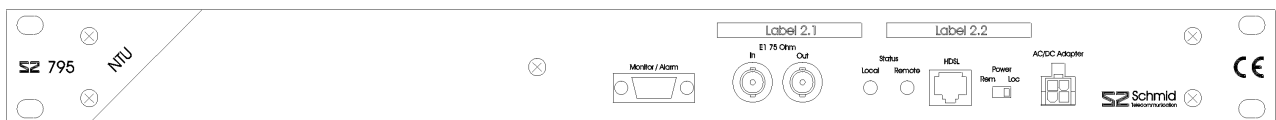

nx64kbit/s

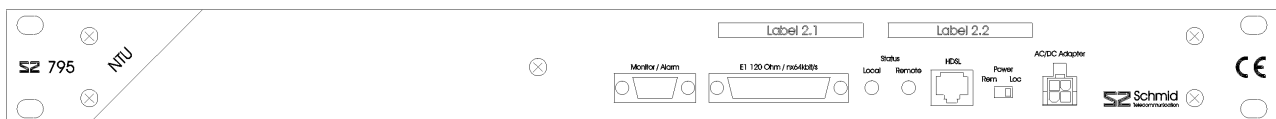

9.3 Plug-in LTU, Front Panel



E1 120Ω

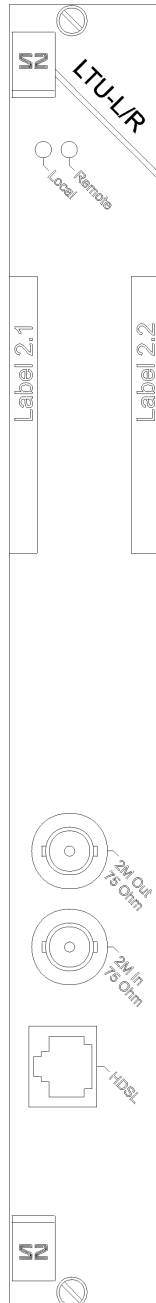

E1 75Ω



Dual 2*E1 120Ω

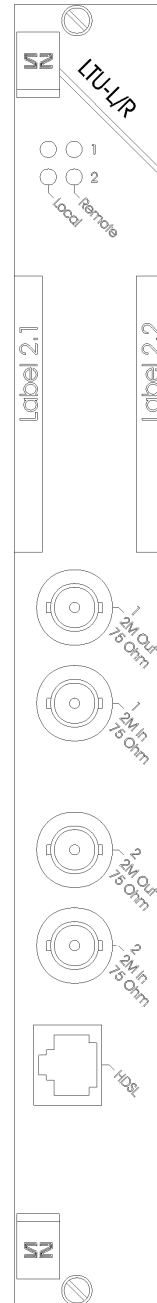

Dual 2*E1 75Ω

9.4 Minirack LTU, Front Panel

Dual 2* E1 120Ω,

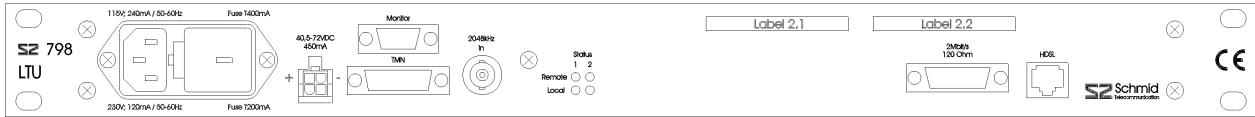

Dual 2* E1 75Ω,

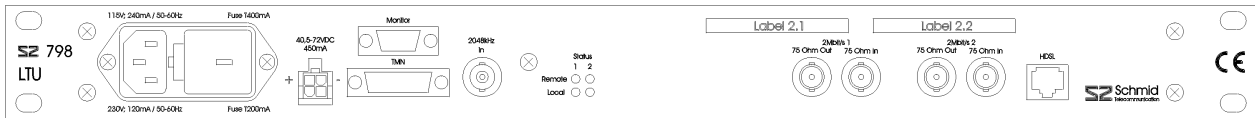

10 Connectors' Description

10.1 DSL Connector

Type: RJ45-8

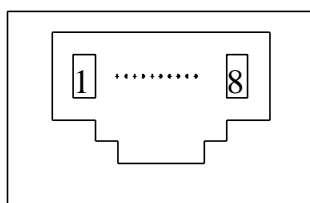

Front View
RJ45-8

Pin	NTU and LTU		LTU (Dual)	
	Signal	Description	Signal	Description
1	NC	-	LD.a	Loop D, tip
2	Shield	DSL cable shield (optional)	LD.b	Loop D, ring
3	LB.a	Loop B, tip	LB.a	Loop B, tip
4	LA.a	Loop A, tip	LA.a	Loop A, tip
5	LA.b	Loop A, ring	LA.b	Loop A, ring
6	LB.b	Loop B, ring	LB.b	Loop B, ring
7	Shield	DSL cable shield (optional)	LC.a	Loop C, tip
8	NC	-	LC.b	Loop C, ring

10.2 E1 Connector

10.2.1 Impedance 120W

LTU:

Type: SubD9 male (Front View)

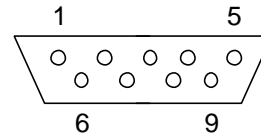

Pin	Signal	Description
1	RXa	E1 120Ω Output (wire A)
2	FPE	Functional Protective Earth (cable shield RX)
3	NC	-
4	FPE	Functional Protective Earth (cable shield TX)
5	TXa	E1 120Ω Input (wire A)
6	RXb	E1 120Ω Output (wire B)
7	NC	-
8	NC	-
9	TXb	E1 120Ω Input (wire B)

Dual LTU:

Type: SubD15 male (Front View)

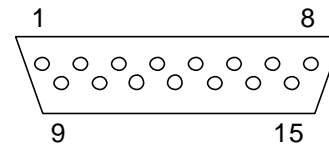

Pin	Signal	Description
1	RX1a	E1 120Ω Output 1 (wire A)
2	FPE	Functional Protective Earth (cable shield RX)
3	TX1a	E1 120Ω Input 1 (wire A)
4	FPE	Functional Protective Earth (cable shield TX)
5	FPE	Functional Protective Earth (cable shield RX)
6	RX2a	E1 120Ω Output 2 (wire A)
7	FPE	Functional Protective Earth (cable shield TX)
8	TX2a	E1 120Ω Input 2 (wire A)
9	RX1b	E1 120Ω Output 1 (wire B)
10	NC	-
11	TX1b	E1 120Ω Input 1 (wire B)
12	NC	-
13	RX2b	E1 120Ω Output 2 (wire B)
14	NC	-
15	TX2b	E1 120Ω Input 2 (wire B)

NTU:

Type: SubD25 female (Front View)

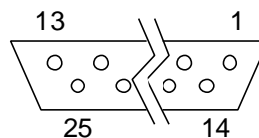

Pin	Signal	Description
1	GND	E1 – Ground
6	RXa	E1 120Ω Output (wire A)
7	GND	E1 – Ground
8	TXa	E1 120Ω Input (wire A)
19	RXb	E1 120Ω Output (wire B)
21	TXb	E1 120Ω Input (wire B)

10.2.2 Impedance 75W

Type: BNC 75Ω

10.3 n x 64kbit/s Connector

10.3.1 User Interface Type

A female SubD25 connector is used for all modes. The table below depicts the pin-out of the connector for the different modes (according to RS-530, ISO 2110) and the signal levels used for the signals.

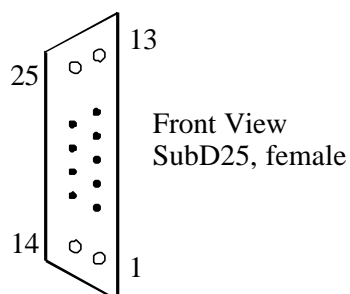

Pin Nr.	i/o	ITU-T Number			Signal Level		
		V.35	V.36	X.21	V.35	V.36	X.21
1		FGND	FGND	FGND			
2	i	103A	103A	TA	V.35	V.11	V.11
3	o	104A	104A	RA	V.35	V.11	V.11
4	i	105	105A	CA	V.28	V.11	V.11
5	o	106	106A	IA	V.28	V.11	V.11
6	o	107	107A		V.28	V.11	
7		102	102	G			
8	o	109	109A		V.28	V.11	
9	o	115B	115B	BB	V.35	V.11	V.11
10	o		109B			V.11	
11	i	113B	113B	XB	V.35	V.11	V.11
12	o	114B	114B	SB	V.35	V.11	V.11
13	o		106B	IB		V.11	V.11
14	i	103B	103B	TB	V.35	V.11	V.11
15	o	114A	114A	SA	V.35	V.11	V.11
16	o	104B	104B	RB	V.35	V.11	V.11
17	o	115A	115A	BA	V.35	V.11	V.11
18	i	141	141		V.28	V.10	
19	i		105B	CB		V.11	V.11
20	i	108/2	108/2A	BIA	V.28	V.11	V.11
21	i	140	140		V.28	V.10	
22	o		107B			V.11	
23	i		108/2B	BIB		V.11	V.11
24	i	113A	113A	XA	V.35	V.11	V.11
25	o	142	142		V.28	V.10	

The ITU-T Numbers are according to ITU-T V.24 (V.35, V.36) and ITU-T X.24 (X.21):

ITU-T Number	Description	From DCE	To DCE
102, G, SGND	Signal Ground		
103, T	Transmitted data		x
104, R	Received data	x	
105, C	Request to send		x
106, I	Clear to send	x	
107	Data set ready	x	
108/2	Data terminal ready		x
109	Data channel received line signal detector	x	
113, X	Codirectional transmit clock, the transmitted data will be sampled with the rising edge.		x
114	Contradirectional transmit clock, the transmitted data will be sampled with the rising edge.	x	
115, S	Receive clock, the received data will be sampled with the rising edge.	x	
140	Remote loopback		x
141	Local loopback		x
142	Test Mode	x	
B	Byte timing, OFF during the first half of the last bit of a byte.	x	
BI	Byte timing input (proprietary designation)		x

The interface is of type DCE, use the appropriate adapter cable for a DTE connector or the standard connectors ISO 2593 for V.35, ISO 4902 for V.36, ISO 4903 for X.21.

10.3.2 n x 64kbit/s Cables

10.3.2.1 V.35 DTE Cable

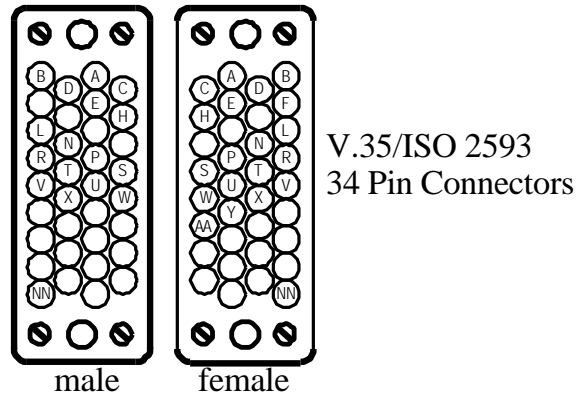

Connector Type : 34 pin (ISO 2593), female

ITU-T Number	Pin Assignment 34 pin female (a/b)	Pin Assignment 25 pin male (a/b)
FGND	A	1
SGND	B	7
103	P/S	2/14
104	R/T	3/16
105	C	4
106	D	5
107	E	6
108	H	20
109	F	8
113	U/W	24/11
114	Y/AA	15/12
115	V/X	17/9
140	N	21
141	L	18
142	NN	25

10.3.2.2 V.35 DCE Cable

Connector Type : 34 pin (ISO 2593), male

ITU-T Number	Pin Assignment 34 pin male (a/b)	Pin Assignment 25 pin male (a/b)
FGND	A	1
SGND	B	7
103	P/S	3/16
104	R/T	2/14
105	C	5
106	D	4
107	E	20
108	H	6
109	-	-
113	U/W	17/9
114	-	-
115	V/X	24/11
140	N	25
141	L	25
142	NN	18

10.3.2.3 V.36 DTE Cable

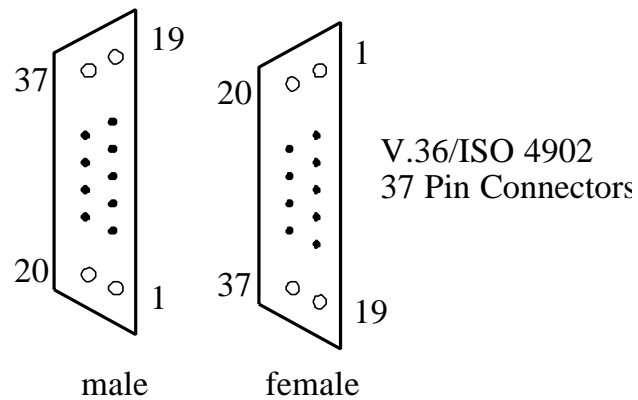

Connector Type : 37 pin (ISO 4902), female

ITU-T Number	Pin Assignment 37 pin female (a/b)	Pin Assignment 25 pin male (a/b)
FGND	1	1
SGND	19	7
SGND(a)	37	7
SGND(b)	20	7
103	4/22	2/14
104	6/24	3/16
105	7/25	4/19
106	9/27	5/13
107	11/29	6/22
108	12/30	20/23
109	13/31	8/10
113	17/35	24/11
114	5/23	15/12
115	8/26	17/9
140	14	21
141	10	18
142	18	25

10.3.2.4 V.36 DCE Cable

Connector Type : 37 pin (ISO 4902), male

ITU-T Number	Pin Assignment 37 pin male (a/b)	Pin Assignment 25 pin male (a/b)
FGND	1	1
SGND	19	7
SGND(a)	37	7
SGND(b)	20	7
103	4/22	3/16
104	6/24	2/14
105	7/25	5/13
106	9/27	4/19
107	11/29	20/23
108	12/30	6/22
109	-	-
113	17/35	17/9
114	-	-
115	8/26	24/11
140	14	25
141	10	25
142	18	18

10.3.2.5 X.21 DTE Cable

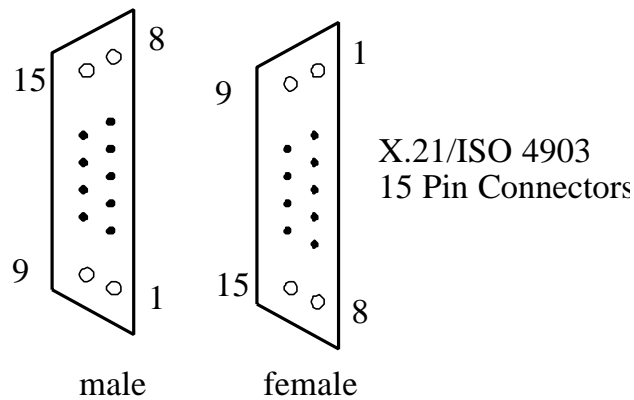

Connector Type : 15 pin (ISO 4903), female

ITU-T Number	Pin Assignment 15 pin female (a/b)	Pin Assignment 25 pin male (a/b)
FGND	1	1
G	8	7
S	6/13	15/12
R	4/11	3/16
T	2/9	2/14
C	3/10	4/19
I	5/12	5/13
B	7/14	17/9 ¹⁾
BI	(7/14) ¹⁾	20/23 ¹⁾

Note:

1) Pins 17-20 and 9-23 have to be connected inside the 25 pin connector.

Alternatively, when the codirectional clock X is used, but no byte clock, this cable can be used:

ITU-T Number	Pin Assignment 15 pin female (a/b)	Pin Assignment 25 pin male (a/b)
FGND	1	1
G	8	7
S	6/13	15/12
R	4/11	3/16
T	2/9	2/14
C	3/10	4/19
I	5/12	5/13
X	7/14	24/11

10.3.2.6 X.21 DCE Cable

Connector Type : 15 pin (ISO 4903), male

ITU-T Number	Pin Assignment 15 pin male (a/b)	Pin Assignment 25 pin male (a/b)
FGND	1	1
G	8	7
S	6/13	24/11
R	4/11	2/14
T	2/9	3/16
C	3/10	5/13
I	5/12	4/19
B	7/14	20/23

Alternatively, when the codirectional clock X is used, but no byte clock, this cable can be used:

ITU-T Number	Pin Assignment 15 pin female (a/b)	Pin Assignment 25 pin male (a/b)
FGND	1	1
G	8	7
S	6/13	24/11
R	4/11	2/14
T	2/9	3/16
C	3/10	5/13
I	5/12	4/19
X	7/14	15/12

10.4 Monitor Connector (NTU)

Type: SubD9 female (Front View)

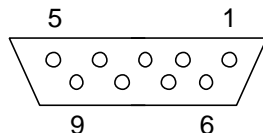

Pin	Signal	Description
1	NC	-
2	TXD	RS-232 Transmit Data
3	RXD	RS-232 Receive Data
4	ALACOM	Common contact of Alarm relay
5	SGND	RS-232 Signal Ground
6	DA_NC	Urgent-Alarm contact, normally closed
7	DA_NO	Urgent-Alarm contact, normally open
8	ND_NC	Non Urgent-Alarm contact, normally closed
9	ND_NO	Non Urgent-Alarm contact, normally open

10.5 Monitor Connector (LTU in Minirack)

Type: SubD9 female (Front View)

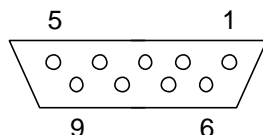

Pin	Signal	Description
1	SGND	RS-232 Signal Ground
2	TXD	RS-232 Transmit Data
3	RXD	RS-232 Receive Data
4	NC	
5	SGND	RS-232 Signal Ground
6	NC	
7	NC	
8	NC	
9	NC	

Use a standard RS-232 cable female - male (SubD9) for connection to a computer or terminal.

10.6 48V_{DC} Power Connector (NTU)

Type: Molex Minifit Junior, safety approved connector to the line adapter with snap-in characteristic.

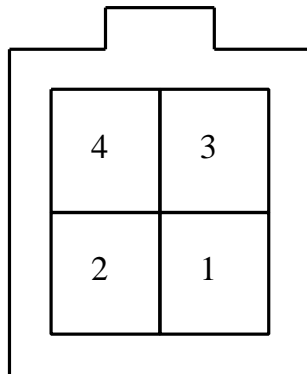

Frontview
Molex-Type Power Connector

Pin	Signal	Description
1	-PWR	Negative power supply terminal for mains adapter
2	PROT	Connected to the center taps of the gas absorbers at the DSL line input
3	NC	Not connected
4	+PWR	Positive power supply terminal for mains adapter

10.7 48V_{DC} Supply (Minirack)

Type: Molex, safety approved connector to the line adapter with snap-in characteristic.

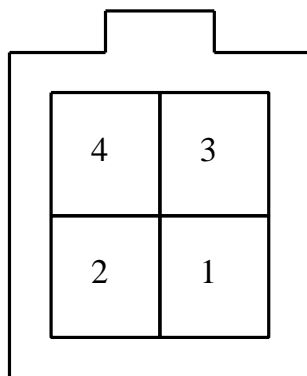

Frontview
Molex-Type Power Connector

Pin	Signal	Description
1	NC	Not connected
2	NC	Not connected
3	-PWR	Negative terminal for battery power supply (fused)
4	+PWR	Positive power supply terminal

10.7.1 Mains Connector (Minirack LTU only)

Contains the 230/115V_{rms} selector and two IEC127 fuses. The values for the fuses are 2xT500mA for 115V, and for 230V they are 2xT250mA.

The connector Type is an IEC 320 C14.

10.7.2 2048kHz Input (Minirack LTU only)

External Clock Input

Type: BNC 75Ω

The input is transformer-coupled.

10.7.3 TMN Alarms (Minirack LTU only)

This is the connector for alarm relay contacts and for the RS485 interface.

Type: SubD15, female

Pin	Signal	Description
1	GND	Protective Ground (connected to pin 8)
2	RX_485+	RS485-Input, (positive)
3	NC	Not connected
4	TX_485+	RS485-Output, (positive)
5	NC	Not connected
6	NAL_NO	Non-Urgent Alarm: Contact Normally Open
7	DAL_NO	Urgent Alarm: Contact Normally Open
8	SGND_485	RS485 Signal Ground (connected to pin 1)
9	RX_485-	RS485-Input, (negative)
10	NC	Not connected
11	TX_485-	RS485-Output, (negative)
12	NC	Not connected
13	NAL_NC	Non-Urgent Alarm: Contact Normally Closed
14	DAL_NC	Urgent Alarm: Contact Normally Closed
15	AL_COM	Common for Urgent and Non-Urgent Alarms (Alarm relays)

11 Technical Specifications

11.1 Interfaces

11.1.1 DSL Line Interface

Norm referred:	ETSI TS 101 135
Number of Pairs:	2
Line Rate per Pair:	1168kbit/s \pm 32ppm (ETSI-Clock-Mode)
Line Code:	2B1Q
Nominal Line Impedance:	135 Ω
Transmit Power:	13.5dBm @ 135 Ω
Signal Bandwidth:	0 .. 287kHz (-3dB)
Overvoltage Protection:	LTU: ITU-T Rec. K.20 NTU: ITU-T Rec. K.21
Connector Type:	RJ-45, 8 pin

11.1.2 User Interface

E1:

Norm referred:	ITU-T Rec. G.703 / G.704
Bit Rate:	2048kbit/s \pm 50ppm
Line Code:	HDB3
Framing:	ITU-T G.704 / transparent
Input Impedance:	120 Ω 75 Ω
Signal Amplitude:	\pm 3.00V @ 120 Ω \pm 2.37V @ 75 Ω
Jitter Performance:	According to ITU-T Rec. G.823
ESD - Protection:	8kV (Air discharge)
Connector Type:	LTU: SubD9 male 120 Ω or BNC 75 Ω NTU: SubD25 female 120 Ω or BNC 75 Ω

PRA:

Norm referred:	ETS 300 233, ETS 300 011, ETS 300 046
----------------	---------------------------------------

n x 64kbit/s:

	V.35	V.36	X.21
Bit Rate:	nx64 kbit/s (n=1..32)		
Signal Levels:			
Data Lines:	ITU-T V.35	ITU-T V.11	ITU-T V.11
Clock Lines:	ITU-T V.35	ITU-T V.11	ITU-T V.11
Control Lines:	ITU-T V.28	ITU-T V.11/V.10	ITU-T V.11
ESD-Protection:	8kV (Air discharge)		
Connector Type HDSL:	SubD25 (ISO 2110), female	SubD25 (RS 530), female	SubD25 female
Connector Type Cable:	34 pin (ISO 2593)	37 pin (ISO 4902)	15 pin (ISO 4903)

11.1.3 Monitor Interface

Signal Level:	RS-232
Data Rate:	9600 Baud, Asynchronous
Protocol:	8 Bit, No Parity, 1 Stop Bit No Linefeed with Carriage Return XON/XOFF enabled
Connector Type:	SubD9 female

11.1.4 TMN and Alarm Interface (Minirack LTU Only)

Connector Type: SubD15, female

TMN:

Signal Level:	TIA/EIA-485 == RS-485
Data Rate:	max 9600 Baud, Asynchronous
Protocol:	SZ Proprietary

Alarm Relays:

Max. Switching power	30W
Max. Switching current	1A
Max. Switching voltage	110V _{DC} , 125V _{rms}
Electrical isolation contact-coil	100V _{rms} for 1min

Note: As the RS485 bus requires a 120Ω termination impedance, hence a cable connector attached to the last minirack-LTU in a chain has to provide the bus termination.

11.1.5 The 230/115V_{rms} and 48V_{DC} Supply of the Minirack

The minirack containing the LTU can be powered either from the 230/115V_{rms} mains or from a 48V_{DC} supply or from both.

The 230/115V_{rms} power entry module can be selected between 230 or 115V_{rms}. Changing the mains option must be complemented by replacing both mains fuses. The 230/115V_{rms} supply module contains the mains transformer, which galvanically separates the minirack circuitry from the mains.

The 48V_{DC} supply input is inverse-polarity proof and is also protected with a 1A slow-blow fuse. The 48V_{DC} voltage delivered to the LTU or NTU is buffered with a 1500μF capacitor. In the case of a power-fail, the stored energy assures that the power-fail alarm is asserted before the power shut-down by at least 60ms.

11.1.6 External Clock

The LTU-Minirack equipped with an external 2048 kHz clock input option contains a module designed to receive and supervise the external clock. The external clock input is a 75Ω BNC type and is coupled to the module via a transformer, providing a physical isolation barrier of up to 1500V_{rms}.

The clock input is converted to TTL levels and is delivered to the LTU. This allows for the LTU's E1 interface to be synchronized to a central master clock, if needed.

The clock input accepts a 2048kHz signal with a peak voltage range from 375mVp-p to 3Vp-p, without disruption to the clock delivery. This allows for a connection between a clock source and the clock input, having an insertion loss of max. 6dB (according to ITU-T G.703, Sec.10, the minimum clock peak voltage must be not less than 1.5Vp-p).

Below the 375mVp-p the Loss of External Clock (LOXCK) alarm is asserted. The LOXCK signal switches on-off threshold has a hysteresis of about 25mV.

11.2 Power Supply

11.2.1 LTU

Local Powering:	-40.5V _{DC} .. -72V _{DC}
-----------------	--

Power Consumption:

	remote power off	remote power on	
		total	local
SZ.363.V510 SZ.363.V530	4.4W	14.8W @2*2.4km REG+NTU	7.1W
SZ.363.V511 SZ.363.V533	5.6W	27.5W @2* 2km REG+REG	8.4W

11.2.2 NTU

Power Consumption:

	local power	remote power
Supply voltage	-40.5V _{DC} .. -72V _{DC}	-120V _{DC} .. -65V _{DC} at NTU DSL-Connector
SZ.364.V510 SZ.364.V530	2.9W	2.5 W
SZ.364.V580	3W	2.75W

11.2.3 REG

Power Consumption:

	local power	remote power
Supply voltage	-	-120V _{DC} .. -65V _{DC} at DSL-Connector
SZ.372.V2	-	3.4W (25°C) 3.8 W (-25°C)

11.3 Environment

11.3.1 Climatic Conditions

Storage:	ETS 300 019-1-1 Class 1.2	-25°C ... +55°C
Transportation:	ETS 300 019-1-2 Class 2.3	-40°C ... +70°C
Operation:	ETS 300 019-1-3 Class 3.2	-5°C ... +45°C
	ETS 300 019-1-3 Class 3.3	-25°C ... +55°C only for REG

11.3.2 Safety

According to EN 60950

11.3.3 EMC

According to EN 300386-2

11.4 Physical Dimensions

11.4.1 LTU

19" Plug-in unit: height: 259mm (6 HE), width: 30mm

Minirack LTU: height: 43.5mm, width: 483mm, depth: 230mm

PCB dimensions: height: 233.35mm, length: 220mm

11.4.2 NTU

Tabletop unit: width 220mm, depth 195mm, height 43mm

Minirack NTU: height: 43.5mm, width: 483mm, depth: 230mm

12 Diagnostics and Troubleshooting

12.1 Test Loops

Standard Test Loops

The test loops can be activated via the monitor interface for both the master and the slave side. However, only one test loop can be activated at any one time. Activation of a further test loop will deactivate the previous loop. A system reset will deactivate any pending test loop.

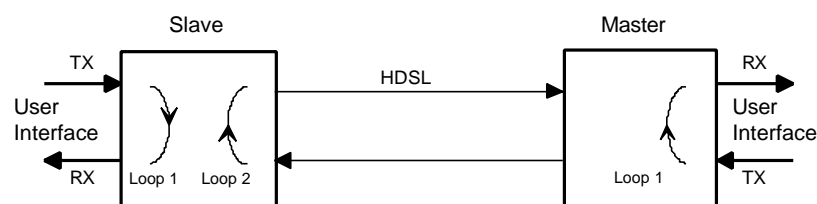

Figure 12-20: Standard Test Loops

Notes:

- On the slave side, Loop 1 can only be activated locally, while Loop 2 can only be activated remotely by the master. Both the “Status Local” LED on the slave and the “Status Remote” LED on the master will be lit amber when a loopback is active.
- On the master side, Loop 1 can only be activated locally. Activating Loop 2 turns on Loop 2 at the slave station. The “Status Local” LED will be lit amber when Loop 1 is active.

Analog Loopback

To test the DSL equipment itself, the Analog Loopback can be used. To perform this test, the DSL - cable has to be disconnected from the unit, which must be configured as master. The test can then be activated with the appropriate monitor command (see chapter “Monitor”).

During the Analog Loopback Test, the DSL transceiver receives the signal of its own transmitter due to the impedance mismatch in the DSL line transformer.

All data of the user interface is looped back according to the interface settings. No other test loop can be activated during Analog Loopback, which in turn can only be deactivated by means of a system reset or power-up. If activated, the Analog Loopback sets off a non-urgent alarm.

Regenerator Loopback:

When using a regenerator, the master can activate an additional loopback in the regenerator:

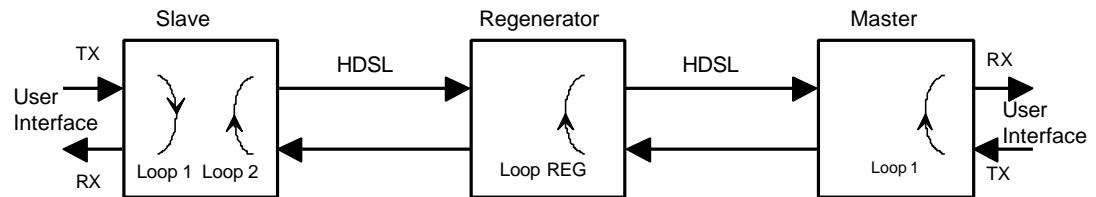

Figure 12-21: Regenerator Loopback

During Regenerator Loopback operations, DSL frames coming from the LTU are looped back to the LTU while the return path from the NTU is open. When a Regenerator Loopback is activated, the following two restrictions must be considered:

- NTU (Slave) is not available by means of EOC related management functions.
- No startups are performed on the second REG-NTU section. However, if the REG-NTU section was running prior to the activation of the Regenerator Loopback, the second section will remain active.

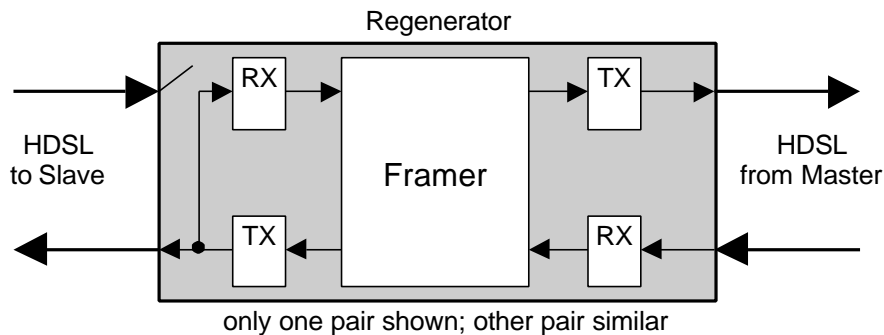

Figure 12-22: Regenerator in Loopback Mode

If activated, the Regenerator Loopback causes the following alarms:

- LOOPREG, indicating that Regenerator Loopback command was entered (LTU-R only).
- REG-A and REG-B, indicating that regenerator has executed the loopback command.

12.2 Hints for Troubleshooting

Problem

No response from the modem

To do:

- Please check your physical serial connection.
- Does the PC/cable combination work on other

- modems?
- Is it the correct cable (see manual section "Cables")?
 - Is the cable grounding correctly connected (floating ground)? Check cable.
 - Please check your baud rate, COM1, COM2, etc configuration on the PC (see chapter "Monitor").
 - Try typing <Control-Q> which is XON and <ECHO>, (to re-enable communication to LTUs occasionally left in XOFF state)
 - Try selecting the modem using <%n>, n being modem address. (See chapter "Monitor").
- Strange signs are received in response from the modem.
- Check baud rate of PC
 - Try typing <Control-Q> which is X-on and <ECHO>
- Problems with E1 clock (frequency, drift, slips):
- Check configuration: Do not configure the E1 interfaces at both ends to use the receive clock as transmit clock except if one DSL equipment is an LTU using the "External Clock" option. Otherwise there will be no defined clock.
- No startup
- If both system units are configured as master or as slave, no start-up will occur. To identify the master unit, check if both LED's are lit ,ON' The slave has only the local LED turned on.
 - Check that you use twisted pair cables till to the end of DSL RJ-45 connector. Do not use other cable types as twisted pairs.

13 Appendix

13.1 Abbreviations

2B1Q	2 Binary - 1 Quaternary
ACO	Alarm Cut Off
ACU	Alarm Control Unit
AIS	Alarm Indication Signal
AIS-R	Alarm Indication Signal (Alarm bit in DSL frame)
AIS-S	Alarm Indication Signal Subscriber
BER-H	Block Error Rate High ($\geq 30\%$ according G.826)
BER-L	Block Error Rate Low ($> 15\%$ & $< 30\%$ according G.826)
BER-S	Excessive Block Error Rate (CRC-4 Errors > 805) on Subscriber
CAP	Carrierless Amplitude Phase Modulation
CCITT	International Telegraph and Telephone Consultative Committee
CCS	Common Channel Signaling
CMU	Control and Management Unit
CRC	Cyclic Redundancy Check
DSL	Digital Subscriber Loop
E1	ITU-T G.703 User Interface at 2048 kbit/s
ET	Exchange Termination
EOC	Embedded Operations Channel
ESR	Errored Second Ratio (G.826)
FAS	Frame Alignment Signal
FC	Failure Condition
FEBE	Far End Block Error
frE1	Fractional E1
HDSL	High Bit Rate Digital Subscriber Loop
HRP	HDSL Regenerator Present

ISDN	Integrated Services Digital Network
ITU-T	International Telecommunication Union
LFA	Loss of Frame Alignment
LFA-L	Loss of Frame Alignment DSL
LFA-S	Loss of Frame Alignment Subscriber
LOS-L	Loss of Signal
LOS-S	Loss of Signal Subscriber side
LT	Line Termination
LTU	Line Termination Unit
MSDSL	Multi-rate Symmetrical DSL
NC	Not Connected
NEXT	Near End Cross Talk
NM	Noise Margin
NT	Network Termination
NTU	Network Termination Unit
PDH	Plesiochronous Digital Hierarchy
PRA	Primary Rate Access
RCBE	Regenerator Central Block Error
RRBE	Regenerator Remote Block Error
Rx	Receive
SDH	Synchronous Digital Hierarchy
SESR	Severely Errored Second Ratio (G.826)
SMF	Sub-Multiframe
SNMP	Simple Network Management Protocol
SQ	Signal Quality
TE	Terminal Equipment
TMN	Telecommunication Management Network
Tx	Transmit
UIF	User Interface
UTP	Unshielded Twisted Pair
XVR	Transceiver

13.2 Referenced Documents

- [1] EN 55024: "Information technology equipment - Immunity characteristics - Limits and methods of measurement (CISPR 24: 1997, modified)".
- [2] EN 55022: "Information technology equipment - Radio disturbance characteristics - Limits and methods of measurement (CISPR 22: 1997, modified)".
- [3] EN 300 386-2: "Electromagnetic compatibility and radio spectrum matters (ERM); Telecommunication network equipment; Electro-Magnetic Compatibility (EMC) requirements; Part 2: Product family standard".
- [4] EN 60950, "Safety of Information Technology Equipment Including Electrical Business Equipment"
- [5] ETS 300 011, "Integrated Services Digital Network (ISDN); Primary rate user-network interface. Layer 1 specification and test principles"
- [6] ETS 300 019, "Equipment Engineering; Environmental Conditions and Environmental Tests for Telecommunications Equipment"
- [7] ETS 300 046, "Integrated Services Digital Network (ISDN); Primary rate access - safety and protection"
- [8] ETS 300 233, "Integrated Services Digital Network (ISDN); Access digital section for ISDN primary rate"
- [9] ETSI TS 101 135 V1.5.1, "Transmission and Multiplexing (TM); High bit-rate Digital Subscriber Line (HDSL) transmission system on metallic local lines; HDSL core specification and applications for 2048 kbit/s based access digital sections"
- [10] ITU-T G.703, "Physical/Electrical Characteristics of Hierarchical Digital Interfaces"
- [11] ITU-T G.704, "Synchronous Frame Structures Used at Primary and Secondary Hierarchical Levels"
- [12] ITU-T G.821, "Error Performance of an International Digital Connection Forming Part of an Integrated Services Digital Network"
- [13] ITU-T G.823, "The Control of Jitter and Wander within Digital Networks Which Are Based on the 2048 kbit/s Hierarchy"
- [14] ITU-T G.826, "Error Performance Parameters and Objectives for International, Constant Bit Rate Digital Paths at or above the Primary Rate"
- [15] ITU-T G.962, "Access Digital Section for ISDN Primary Rate Access at 2048 kbit/s"
- [16] ITU-T I.604, "Application of Maintenance Principles to ISDN Primary Rate Accesses"
- [17] ITU-T K.20, "Resistibility of Telecommunication Switching Equipment to Overvoltages and Overcurrents"
- [18] ITU-T K.21, "Resistibility of Subscribers' Terminals to Overvoltages and Overcurrents"
- [19] ITU-T V.10, "Electrical Characteristics for Unbalanced Double-Current Interchange Circuits Operating at Data Signaling Rates Nominally up to 100 kbit/s"
- [20] ITU-T V.11, "Electrical Characteristics for Balanced Double-Current Interchange Circuits Operating at Data Signaling Rates up to 10 Mbit/s"

- [21] ITU-T V.24, "List of Definitions for Interchange Circuits between Data Terminal Equipment (DTE) and Data Circuit-Terminating Equipment (DCE)"
- [22] ITU-T V.28, "Electrical Characteristics for Unbalanced Double-Current Interchange Circuits"
- [23] ITU-T V.35, "Data Transmission at 48 kbit/s Using 60-108 kHz Group Band Circuits"
- [24] ITU-T V.36, "Modems for Synchronous Data Transmission Using 60-108 kHz Group Band Circuits"
- [25] ITU-T V.54, "Loop Test Devices for Modems"
- [26] ITU-T X.21, "Interface between Data Terminal Equipment and Data Circuit-Terminating Equipment for Synchronous Operation on Public Data Networks"
- [27] ITU-T X.24, "List of Definitions for Interchange Circuits between Data Terminal Equipment (DTE) and Data Circuit-Terminating Equipment (DCE) on Public Data Networks"
- [28] ISO 2593, "Connector pin allocations for use with high-speed data terminal equipment", 1973.
- [29] ISO 2110, "Data communication - 25-pin DTE/DCE interface connector and pin assignments", 1980.
- [30] ISO 4902, "Data communication - 37-pin and 9-pin DTE/DCE interface connectors and pin assignments", 1980.
- [31] ISO 4903, "Data communication - 15-pin DTE/DCE interface connector and pin assignments", 1980.